

BERIC®

FORGED STEEL TECHNICAL DATA

Valves



WWW.BERICVALVES.COM



Valves

Table of Contents

CLASS, MATERIALS AND SPECIFICATIONS.....	3
FIGURE NUMBER CHART.....	4-5
GATE VALVE (501, 505, 511, 515).....	6
GLOBE VALVE (502, 506, 516, 522).....	7
PISTON CHECK VALVE (503, 507, 517, 523).....	8
SWING CHECK VALVE (504, 508, 514, 518).....	9
GATE VALVE STANDARD PORT.....	10
GLOBE VALVE STANDARD PORT.....	11
PISTON CHECK VALVE STANDARD PORT.....	12
SWING CHECK VALVE STANDARD.....	13
GATE VALVE FULL PORT.....	14
GLOBE VALVE FULL PORT.....	15
PISTON CHECK VALVE FULL PORT.....	16
SWING CHECK VALVE FULL PORT.....	17
Y-PATTERN GLOBE VALVE STANDARD PORT.....	18
Y-PATTERN GLOBE VALVE FULL PORT.....	19
Y-PATTERN PISTON CHECK VALVE STANDARD PORT.....	20
Y-PATTERN PISTON CHECK VALVE FULL PORT.....	21
BALL CHECK VALVE STANDARD PORT.....	22
BALL CHECK VALVE FULL PORT.....	23
EXTENDED BODY GATE VALVE STANDARD PORT.....	24
REINFORCED EXTENDED BODY GATE VALVE STANDARD PORT.....	25
501 CRYOGENIC/EXTENDED BONNET GATE VALVE, STANDARD PORT.....	26
502 CRYOGENIC/EXTENDED BONNET GLOBE VALVE, STANDARD PORT.....	27
BELLOWS SEAL GATE VALVE STANDARD PORT.....	28
BELLOWS SEAL GATE VALVE FULL PORT.....	29
BELLOWS SEAL GLOBE VALVE STANDARD PORT.....	30
BELLOWS SEAL GLOBE VALVE FULL PORT.....	31

Forged Steel Valves Gate, Globe, & Check

ANSI Class:	800, 900, & 1500 For Threaded, Socket Weld and Buttweld Ends 150, 300, 600 & 1500 Flanged Class 1690, 2500, & 2690 Also Available
Materials:	ASTM A 105N – Carbon Steel ASTM A 350 Gr. LF2 – Low Temperature Carbon Steel ASTM A 182 Gr. 316/316L – Stainless Steel ASTM A 182 Gr. F5, F9, F11, F22 – Alloy Steel ASME B16.34 Listed & Non-Listed Materials Available
Specifications:	<p>Designed To The Applicable Requirements Of: API 602, ASME B16.34, BS 5352, & MSS SP-118</p> <p>Tested In Accordance With: API 598 Markings Per MSS SP-25</p> <p>Certified to: API 624 NACE When Specified</p> <p>End Connections: Female Threaded Ends (NPT) to: ASME B1.20.1 Female Socket Weld Ends to: ASME B16.11 Male Threaded Ends (NPT) to: API 602 Plain Ends [PE] to: API 602 Butt Welding Ends to: ASME B16.25 Flanged Ends to: ASME B16.5 & B16.10</p>





Valves

Valve Style		End Connection		Size		Class	
501	BB Gate	B(SCH)	Butt Weld	1	1/4	1	#150
502	BB Globe	F	Flanged	2	3/8	3	#300
503	BB Piston Check	G	Flat Face Flange	3	1/2	6	#600
504	BB Swing Check	H	MNPT X FNPT	4	3/4	8	#800
505	WB Gate	J	MNPT X FSW	5	1	9	#1500
506	WB Globe	K	MSW X FNPT	6	1 1/4	0	#2500
507	WB Piston Check	L	MSW X FSW	7	1 1/2	A	#900
508	WB Swing Check	R	RTJ	8	2	B	#1690
509	BB Y-Pattern Globe	S	Socket Weld			C	#2690
510	BB Y-Pattern Check	T	NPT				
511	FP BB Gate	W	FNPT X SW				
512	WB Y-Pattern Globe	X	SW X FNPT				
513	WB Y-Pattern Check	Y	RMSW X FNPT				
514	FP BB Swing Check	Z	RMSW X FSW				
515	FP WB Gate						
516	FP WB Globe						
517	FP WB Piston Check						
518	FP WB Swing Check						
522	FP BB Globe						
523	FP BB Piston Check						
530	BB Ball Check						
531	FP BB Ball Check						
532	WB Ball Check						
533	FP WB Ball Check						
552	WB Y-Pattern Stop/Check						
561	Pressure Seal Gate						
562	Pressure Seal Globe						
563	Pressure Seal Piston Check						

1. Beric trim number corresponds to the equivalent API 602 trim designation
2. Not all options are available in combinations.

Please consult Beric Valves. Minimum quantities may apply to certain materials or trim configurations.

FIGURE NUMBER EXAMPLE: 501S48A08NW

Figure Number Chart

Material		Trim	Options	
A	A105N	03 (F310)	C	Chain Operated
B	A350 LF2 (default CL2)	04 (Hard F6)	C1,2...	Material Class Option
C	A182 F5	05 (HF)	D	Extended Bonnet
D	A182 F9	05A (HF)	E	17-4 ph Stem
E	A182 F11	06 (F6 / Cu-Ni)	G	Garlock EVSP Packing
F	A182 F22	07 (F6 / Hard F6)	J	High Temp Packing & Gasket
G	A182 F304/304L	08 (F6 / HF)	K	Live Loaded Packing
H	A182 F316/316L	08A (F6 / HF)	L	Locking Device (CSO/CSC)
J	A182 F321	09 (Monel™)	M	Mounting Plate
K	A182 F52	10 (316)	N	NACE
M	A182 F347	11 (Monel™ / HF)	O	Oxygen Cleaned
N	A350-LF3	12 (316 / HF)	P	Position Indicator
P	A182 F12	13 (Alloy 20)	T	TFE Packing, 316/TFE Gasket
Q	A182 P91	14 (Alloy 20 / HF)	U	316/TFE Gasket Only
R	A182 F51	15 (HF)	V	Vacuum Service
S	A182 F316H	16 (HF)	W	316ss Bellow Seal
T	A182 F317/F317L	17 (HF)	W1	321ss Bellow Seal
U	A182 F347H	18 (HF)	X	Nipple Extensions
4	MONEL™ 400	19 (Ni Alloy)	Y	Cryogenic Service
X	Other, Specify	19a (Alloy 625)	Z	Other, specify
		19b (Alloy C276)	A2	HF Alkylation Service
		19c (Alloy 825)		
		20 (Ni Alloy / HF)		
		20a (625 / HF)		
		20b (C276 / HF)		
		20c (825 / HF)		
		21 (HF)		
		99-Other, Specify		
		Obsolete: 01 (F6)		
		Obsolete: 02 (304)		

Gate Valve

Applicable series: 501, 505, 511, 515

Extended Body/Bonnet & Bellows Seal

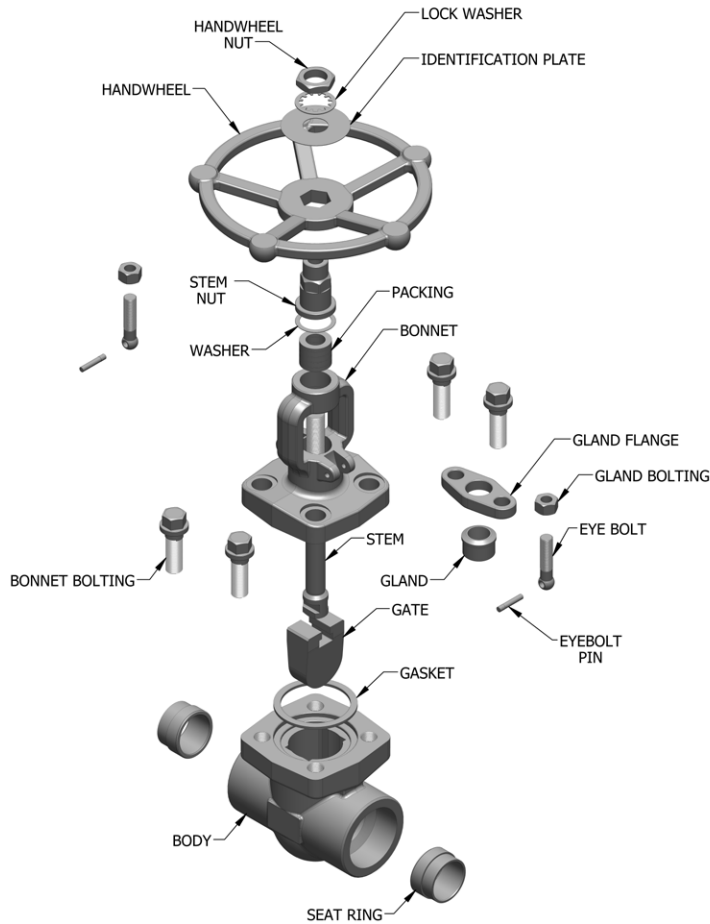

STANDARD MATERIAL LIST									
NO.	Part Name	A105	LF2	F5	F9	F11	F22	F316/F316L	
1	Body	A105N	A350-LF2	A182-F5	A182-F9	A182-F11	A182-F22	A182-F316/F316L	
2	Seat Ring	A276-410/CoCr-A						A276-316/CoCr-A	
3	Gate	A276-420						A276-316	
4	Stem	A276-410						A276-316	
5	Gasket	Spiral Wound 304/Graphite						316/Graphite	
6	Bonnet	A105N	A350-LF2	A182-F5	A182-F9	A182-F11	A182-F22	A182-F316/F316L	
7	Wiper Ring	Braided Graphite							
8	Packing	Die Formed Graphite							
9	Bonnet Bolting	A193-B7	A320-L7	A193-B16				A193-B8M	
10	Eyebolt Pin	A276-304						A276-316	
11	Gland	A276-420						A276-316	
12	Eyebolt	A193-B7	A320-L7	A193-B16				A193-B8M	
13	Gland Flange	A105						A182-F316	
14	Gland Bolting	A194-2H	A194-4	A194-7				A194-8M	
15	Stem Nut	A276-410						A276-410	
16	Washer	A276-410							
17	Identification plate	Aluminum							
18	Handwheel	A197							
19	Handwheel Nut	A108 1020							
20	Lock washer	A276-410							

Globe Valve

Applicable series: 502, 506, 516, 522
Extended Body/Bonnet & Bellows Seal

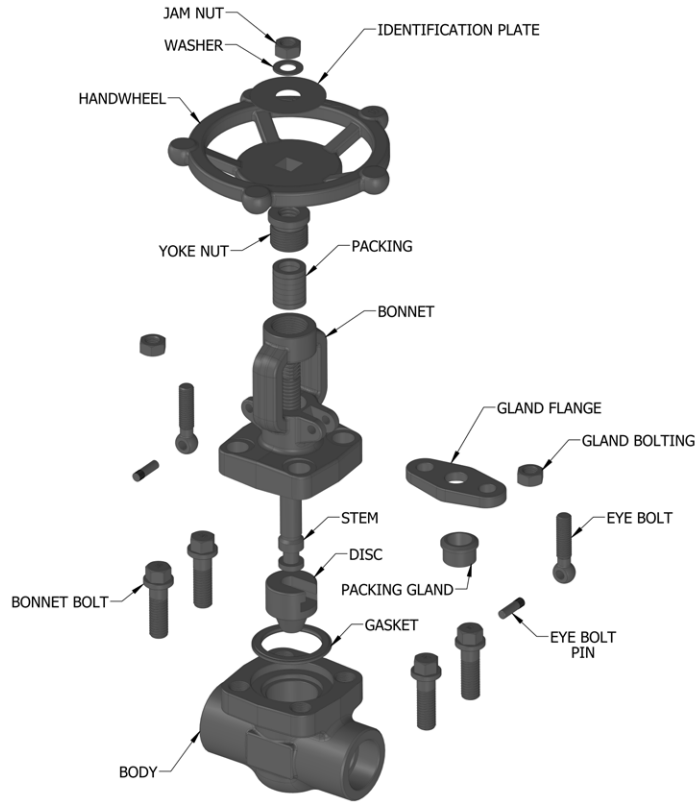

STANDARD MATERIAL LIST									
NO.	Part Name	A105	LF2	F5	F9	F11	F22	F316/F316L	
1	Body	A105N	A350-LF2	A182-F5	A182-F9	A182-F11	A182-F22	A182-F316/F316L	
2	Seat Ring	CoCr-A							A276-F316/CoCr-A
3	Plate	A276-420							A276-316
4	Stem	A276-410							A276-316
5	Gasket	Spiral Wound 304/Graphite							316/Graphite
6	Bonnet	A105N	A350-LF2	A182-F5	A182-F9	A182-F11	A182-F22	A182-F316/F316L	
7	Wiper Ring	Braided Graphite							
8	Packing	Die Formed Graphite							
9	Bonnet Bolt	A193-B7	A320-L7	A193-B16				A193-B8M	
10	Eyebolt Pin	A276-304							A276-316
11	Packing Gland	A276-420							A276-316
12	Eyebolt	A193-B7	A320-L7	A193-B16				A193-B8M	
13	Gland Flange	A105N							A182-F316
14	Gland Bolting	A194-2H	A194-4	A194-7				A194-8M	
15	Yoke Nut	A276-410							
16	Washer	A276-410							
17	Identification plate	Aluminum							
18	Handwheel	A197							
19	Jam Nut	A194-2H							A194-8

Piston Check Valve

Applicable series: 503, 507, 517, 523

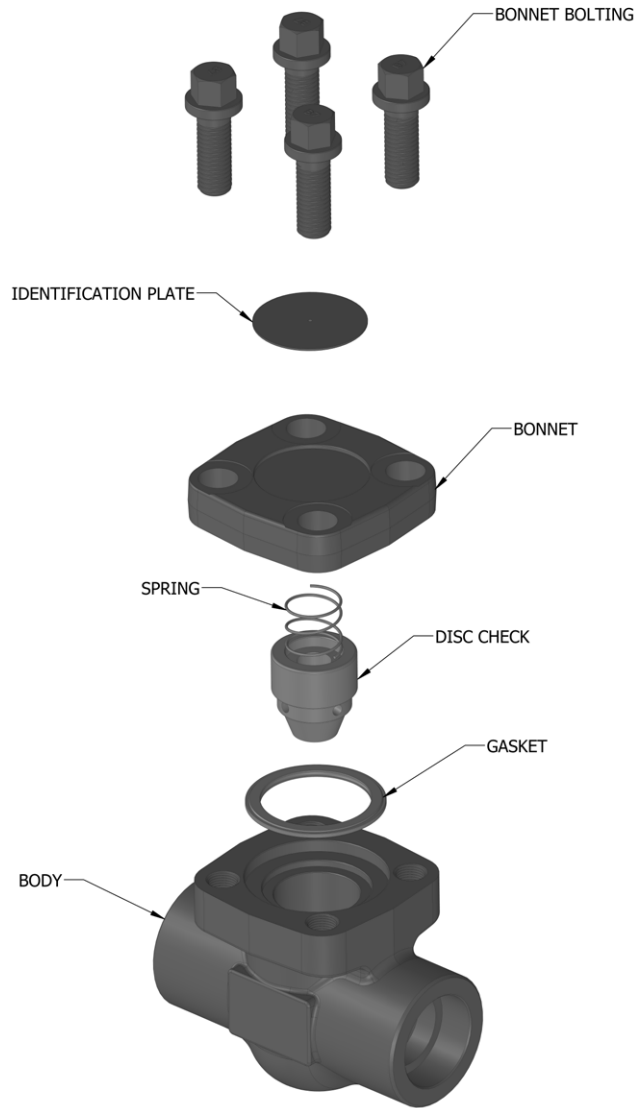

STANDARD MATERIAL LIST

NO.	Part Name	A105	LF2	F5	F9	F11	F22	F316/F316L	
1	Body	A105N	A350-LF2	A182-F5	A182-F9	A182-F11	A182-F22	A182-F316/F316L	
2	Seat	CoCr-A						CoCr-A	
3	Plate Check	A276-420							
4	Spring	A276-316							
5	Gasket	Spiral Wound 304/Graphite							
6	Bonnet	A105N	A350-LF2	A182-F5	A182-F9	A182-F11	A182-F22	A182-F316/F316L	
7	Bonnet Bolting	A193-B7	A320-L7	A193-B16					A193-B8M
8	Identification plate	Aluminum							

Swing Check Valve

Applicable series: 504, 508, 514, 518

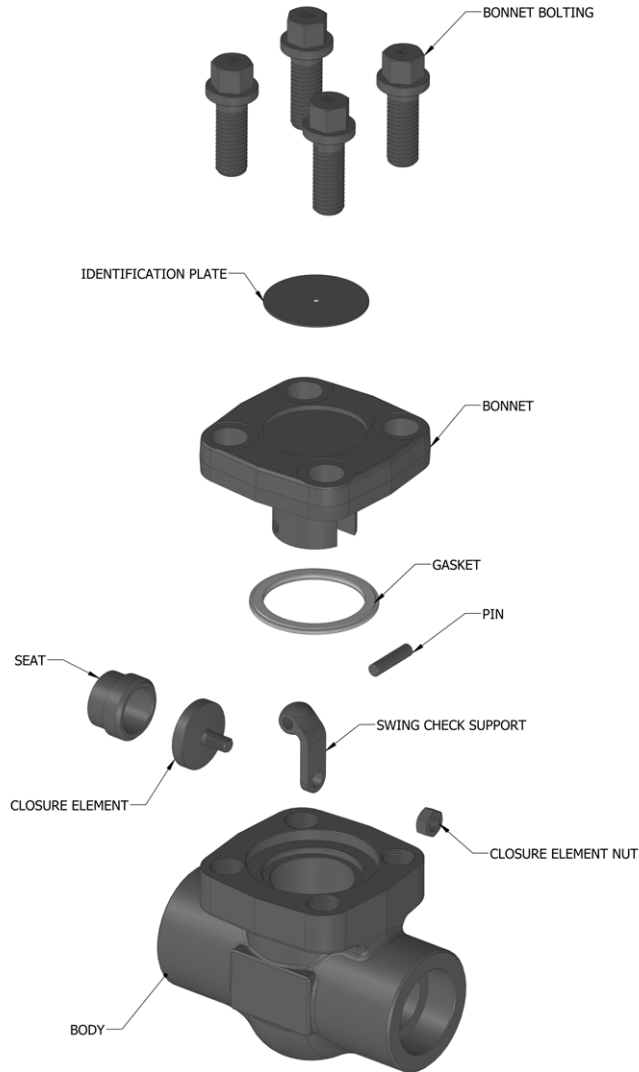

STANDARD MATERIAL LIST									
NO.	Part Name	A105	LF2	F5	F9	F11	F22	F316/F316L	
1	Body	A105N	A350-LF2	A182-F5	A182-F9	A182-F11	A182-F22	A182-F316/F316L	
2	Seat	A276-410/CoCr-A						316/CoCr-A	
3	Closure element	A276-420						A276-316	
4	Closure element Nut	A194-8						A194-8M	
5	Swing Check support	A351-CF8			A351-CF8M				
6	Pin	A276-316							
7	Gasket	Spiral Wound 304/Graphite						316/Graphite	
8	Bonnet	A105N	A350-LF2	A182-F5	A182-F9	A182-F11	A182-F22	A182-F316/F316L	
9	Bonnet Bolting	A193-B7	A320-L7	A193-B16				A193-B8M	
10	Identification plate	Aluminum							

Gate Valve Standard Port

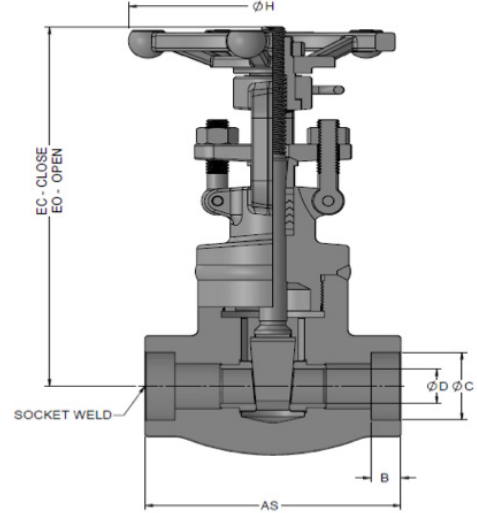
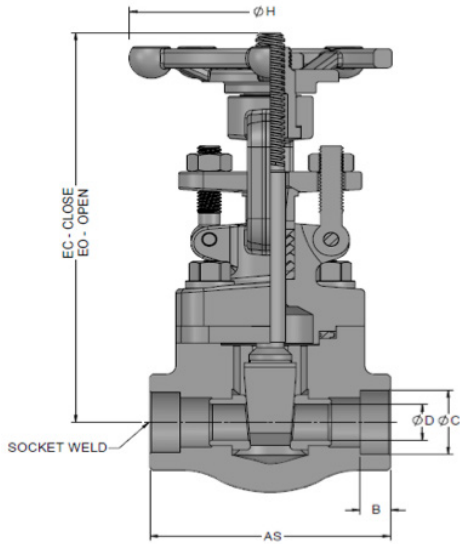

501 Series: Bolted Bonnet

505 Series: Welded Bonnet

STANDARDS				
DESIGN:	API 602	TESTING:	API 598	
	ASME B16.34		CONNECTIONS:	NPT - ASME B1.20.1
	FACE-TO-FACE - ASME B16.10			SW - ASME B16.11
PRESSURE CLASS:	NPT, SW & BW - 800, 1500	BW- ASME B16.25		
	FLANGED - 150, 300, 600, 1500	FLANGED - ASME B16.5		

SIZE		DIMENSIONS														WGT (lb/kg)									
		AT/AS 800	AF-150	AF-300	AF-600	B (Min)	C (Min)	D (Min)-NPT/SW	D(Min)-RF	EC-NPT/SW (501)	EO-NPT/SW (501)	EC-NPT/SW (505)	EO-NPT/SW (505)	EC RF (501)	EO RF (501)	H	150 (501)	150 (505)	300 (501)	300 (505)	600 (501)	600 (505)	800 (501)	800 (505)	
1/4	Inch	3.11	/	/	/	0.39	0.56	0.30	/	5.59	6.18	5.63	6.22	/	/	3.94	/	/	/	/	/	/	/	4.63	3.97
	mm	79.0	/	/	/	10.0	14.2	7.5	/	142.0	157.0	143.0	158.0	/	/	100.0	/	/	/	/	/	/	/	2.1	1.8
3/8	Inch	3.11	/	/	/	0.39	0.69	0.39	/	5.59	6.18	5.63	6.22	/	/	3.94	/	/	/	/	/	/	/	4.63	3.97
	mm	79.0	/	/	/	10.0	17.6	10	/	142.0	157.0	143.0	158.0	/	/	100.0	/	/	/	/	/	/	/	2.1	1.8
1/2	Inch	3.11	4.25	5.51	6.50	0.39	0.86	0.51	0.37	5.59	6.18	5.63	6.22	5.51	6.02	3.94	5.95	7.50	7.72	8.31	8.60	9.26	4.41	3.75	
	mm	79.0	108.0	140.0	165.0	10.0	21.8	13.0	9.5	142.0	157.0	143.0	158.0	140.0	153.0	100.0	2.7	3.4	3.5	3.8	3.9	4.2	2.0	1.7	
3/4	Inch	3.62	4.61	5.98	7.48	0.51	1.07	0.51	0.51	5.59	6.18	5.79	6.38	5.59	6.18	3.94	7.50	8.77	10.14	10.78	11.90	12.79	4.85	4.41	
	mm	92.0	117.0	152.0	190.0	13.0	27.2	13.0	13.0	142.0	157.0	147.0	162.0	142.0	157.0	100.0	3.4	4.0	4.6	4.9	5.4	5.8	2.2	2.0	
1	Inch	4.37	5.00	6.50	8.50	0.51	1.33	0.71	0.71	6.50	7.28	7.01	7.80	6.50	7.28	4.72	11.68	13.49	14.77	15.94	16.53	19.40	7.72	8.38	
	mm	111.0	127.0	165.0	216.0	13.0	33.9	18.0	18.0	165.0	185.0	178.0	198.0	165.0	185.0	120.0	5.3	6.1	6.7	7.2	7.5	8.8	3.5	3.8	
1-1/4	Inch	4.72	5.51	7.01	9.02	0.51	1.68	0.94	0.94	7.87	8.90	8.03	9.06	7.87	8.90	6.30	16.98	19.93	21.16	23.26	24.91	29.50	12.13	12.79	
	mm	120.0	140.0	178.0	229.0	13.0	42.7	24.0	24.0	200.0	226.0	204.0	230.0	200.0	226.0	160.0	7.7	9.0	9.6	10.6	11.3	13.4	5.5	5.8	
1-1/2	Inch	4.72	6.50	7.48	9.49	0.51	1.92	1.14	1.14	8.23	9.49	8.39	9.61	8.27	9.49	6.30	20.94	22.93	26.68	27.87	31.97	34.39	14.11	14.11	
	mm	120.0	165.0	190.0	241.0	13.0	48.8	29.0	29.0	209.0	241.0	213.0	244.0	210.0	241.0	160.0	9.5	10.4	12.1	12.6	14.5	15.6	6.4	6.4	
2	Inch	5.51	7.01	8.50	11.50	0.65	2.41	1.44	1.44	9.02	10.75	9.65	11.18	9.45	11.02	8.66	30.86	34.17	37.70	39.68	45.86	42.99	20.50	22.05	
	mm	140.0	178.0	216.0	292.0	16.5	61.2	36.5	36.5	229.0	273.0	245.0	284.0	240.0	280.0	220.0	14.0	15.5	17.1	18.0	20.8	19.5	9.3	10.0	

SIZE		DIMENSIONS-1500														WGT (lb/kg)					
		AT/AS (501)	AT/AS (505)	AF (501)	AF (505)	B (Min)	C (Min)	D(Min)-RF (501)	D(Min)-NPT/SW	EC-NPT/SW (501)	EO-NPT/SW (501)	EC-NPT/SW (505)	EO-NPT/SW (505)	EC-RF (501)	EO-RF (501)	H-NPT/SW	H-RF (501)	NPT/SW (501)	NPT/SW (505)	RF (501)	
1/2	Inch	4.37	4.37	8.50	NA	0.39	0.86	0.39	0.51	6.50	7.09	7.13	7.72	6.50	7.09	4.72	4.72	8.38	8.60	16.53	
	mm	111.0	111.0	216.0	NA	10.0	21.8	10.0	13.0	165.0	180.0	181.00	196.00	165.0	180.0	120.00	120.0	3.8	3.9	7.5	
3/4	Inch	4.37	4.37	9.02	NA	0.51	1.07	0.51	0.51	6.50	7.09	7.13	7.72	6.50	7.09	4.72	4.72	8.16	8.38	20.94	
	mm	111.0	111.0	229.0	NA	13.0	27.2	13.0	13.0	165.0	180.0	181.00	196.00	165.0	180.0	120.00	120.0	3.7	3.8	9.5	
1	Inch	4.72	4.72	10.00	NA	0.51	1.33	0.71	0.71	7.87	8.66	8.07	8.86	7.87	8.66	6.30	6.30	13.01	13.23	31.97	
	mm	120.0	120.0	254.0	NA	13.0	33.9	18.0	18.0	200.0	220.0	205.00	225.00	200.0	220.0	160.00	160.0	5.9	6.0	14.5	
1-1/4	Inch	4.72	4.72	/	NA	0.51	1.68	/	0.94	8.23	9.25	8.39	9.41	/	/	6.30	/	14.99	14.55	/	
	mm	120.0	120.0	/	NA	13.0	42.7	/	24.0	209.0	235.0	213.00	239.00	/	/	160.00	/	6.8	6.6	/	
1-1/2	Inch	5.51	5.51	12.01	NA	0.51	1.92	1.14	1.14	9.25	10.47	9.76	10.98	10.55	11.77	8.66	8.66	21.38	24.25	61.29	
	mm	140.0	140.0	305.0	NA	13.0	48.8	29.0	29.0	235.0	266.0	248.00	279.00	268.0	299.0	220.00	220.0	9.7	11.0	27.8	
2	Inch	6.30	7.01	14.49	NA	0.65	2.41	1.44	1.44	11.14	12.68	11.02	12.56	12.40	13.94	8.66	10.24	35.93	33.73	102.95	
	mm	160.0	178.0	368.0	NA	16.5	61.2	36.5	36.5	283.0	322.0	280.00	319.00	315.0	354.0	220.00	260.0	16.3	15.3	46.7	

Globe Valve Standard Port

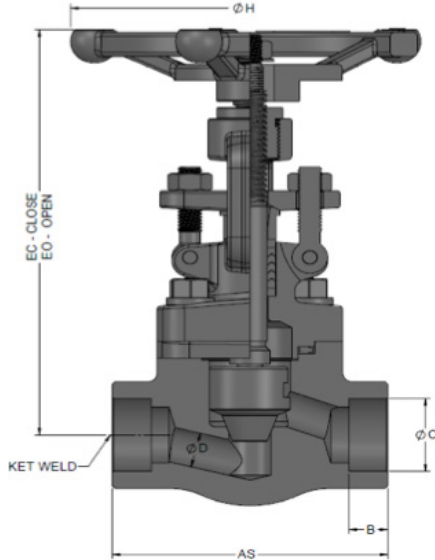

502 Series: Bolted Bonnet

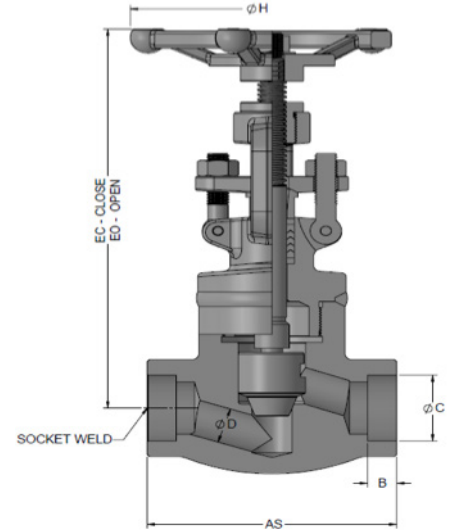

506 Series: Welded Bonnet

STANDARDS				
DESIGN:	API 602	TESTING:	API 598	
	MSS SP-118		CONNECTIONS:	NPT - ASME B1.20.1
	ASME B16.34			SW - ASME B16.11
	FACE TO FACE-ASME B16.10			BW- ASME B16.25
PRESSURE CLASS:	NPT, SW & BW - 800, 1500	FLANGED - ASME B16.5		

DIMENSIONS																	WGT.(lb/kg)									
SIZE		AT/AS 800	AF- 150	AF- 300	AF- 600	B (Min)	C (Min)	D (Min)- NPT/ SW	D (Min)- RF	EC- NPT/ SW (502)	EO- NPT/ SW (502)	EC- NPT/ SW (506)	EO- NPT/ SW (506)	EC RF(502)	EO RF(502)	H	150 (502)	150 (506)	300 (502)	300 (506)	600 (502)	600 (506)	800 (502)	800 (506)		
1/4	Inch	3.11	/	/	/	0.39	0.56	0.27	/	5.87	6.34	6.10	6.54	/	/	3.94	/	/	/	/	/	/	/	/	4.85	4.19
	mm	79.0	/	/	/	10.0	14.2	6.8	/	149.0	161.0	155.0	166.0	/	/	100.0	/	/	/	/	/	/	/	/	2.2	1.9
3/8	Inch	3.11	/	/	/	0.39	0.69	0.27	/	5.87	6.34	6.10	6.54	/	/	3.94	/	/	/	/	/	/	/	/	4.85	4.19
	mm	79.0	/	/	/	10.0	17.6	6.8	/	149.0	161.0	155.0	166.0	/	/	100.0	/	/	/	/	/	/	/	/	2.2	1.9
1/2	Inch	3.11	4.25	5.98	6.50	0.39	0.86	0.37	0.37	5.87	6.34	6.10	6.54	5.87	6.34	3.94	6.39	7.61	7.94	8.38	8.60	12.35	4.63	3.97	2.1	1.8
	mm	79.0	108.0	152.0	165.0	10.0	21.8	9.5	9.5	149.0	161.0	155.0	166.0	149.0	161.0	100.0	2.9	3.5	3.6	3.8	3.9	5.6	2.1	1.8	5.6	2.1
3/4	Inch	4.72	5.51	8.50	9.02	0.51	1.07	0.49	0.49	5.87	6.34	6.10	6.54	5.87	6.34	3.94	7.50	8.82	10.80	11.24	11.68	17.20	5.07	4.41	5.8	5.8
	mm	120.0	140.0	216.0	229.0	13.0	27.2	12.5	12.5	149.0	161.0	155.0	166.0	149.0	161.0	100.0	3.4	4.0	4.9	5.1	5.3	7.8	2.3	2.0	7.8	2.3
1	Inch	4.37	5.00	7.99	8.50	0.51	1.33	0.69	0.69	6.97	7.60	7.60	8.07	6.97	7.60	4.72	11.90	13.65	16.31	15.87	17.42	27.56	8.16	8.38	8.16	8.38
	mm	111.0	127.0	203.0	216.0	13.0	33.9	17.5	17.5	177.0	193.0	193.0	205.0	177.0	193.0	120.0	5.4	6.2	7.4	7.2	7.9	12.5	3.7	3.8	12.5	3.7
1-1/4	Inch	4.72	5.51	8.50	9.02	0.51	1.68	0.93	0.93	8.35	9.06	8.58	9.41	8.35	9.06	6.30	17.64	21.16	25.35	25.35	26.46	37.48	12.79	12.79	12.79	12.79
	mm	120.0	140.0	216.0	229.0	13.0	42.7	23.5	23.5	212.0	230.0	218.0	239.0	212.0	230.0	160.0	8.0	9.6	11.5	11.5	12.0	17.0	5.8	5.8	5.8	5.8
1-1/2	Inch	5.98	6.50	9.02	9.49	0.51	1.92	1.12	1.12	8.82	9.76	9.13	9.88	8.82	9.76	6.30	21.61	23.15	29.98	29.76	32.85	51.81	16.53	16.53	16.53	16.53
	mm	152.0	165.0	229.0	241.0	13.0	48.8	28.5	28.5	224.0	248.0	232.0	251.0	224.0	248.0	160.0	9.8	10.5	13.6	13.5	14.9	23.5	7.5	7.5	7.5	7.5
2	Inch	6.77	7.99	10.51	11.50	0.65	2.41	1.44	1.44	10.16	11.10	10.55	11.42	10.08	11.42	8.66	35.71	37.48	43.43	43.43	48.72	85.54	22.49	26.23	26.23	26.23
	mm	172.0	203.0	267.0	292.0	16.5	61.2	36.5	36.5	258.0	282.0	268.0	290.0	256.0	290.0	220.0	16.2	17.0	19.7	19.7	22.1	38.8	10.2	11.9	11.9	11.9

DIMENSIONS-1500																	WGT.(lb/kg)			
SIZE		AT/AS (502)	AT/AS (506)	AF (502)	B (Min)	C (Min)	D (Min)- NPT/ SW	D (Min)- RF (502)	EC-NPT/ SW (502)	EO- NPT/ SW (502)	EC-NPT/ SW(506)	EO-NPT/ SW (506)	EC-RF (502)	EO-RF (502)	H-RF (502)	H-NPT/ SW	NPT/SW (502)	NPT/SW (506)	RF (502)	
1/2	Inch	4.37	4.37	8.50	0.39	0.86	0.37	0.37	6.97	7.64	7.68	8.23	6.97	7.64	4.72	4.72	8.82	8.82	14.99	
	mm	111.0	111.0	216.0	10.0	21.8	9.5	9.5	177.0	194.0	195.0	209.0	6.97	7.64	120.0	120.0	4.0	4.0	6.8	
3/4	Inch	4.37	4.37	9.02	0.51	1.07	0.49	0.49	6.97	7.64	7.68	8.23	6.97	7.64	4.72	4.72	8.82	8.82	21.16	
	mm	111.0	111.0	229.0	13.0	27.2	12.5	12.5	177.0	194.0	195.0	209.0	6.97	7.64	120.0	120.0	4.0	4.0	9.6	
1	Inch	4.72	4.72	10.00	0.51	1.33	0.69	0.69	8.46	9.13	8.70	9.41	8.46	9.13	6.30	6.30	13.23	13.45	32.63	
	mm	120.0	120.0	254.0	13.0	33.9	17.5	17.5	215.0	232.0	221.0	239.0	215.0	232.0	160.0	160.0	6.0	6.1	14.8	
1-1/4	Inch	5.98	5.98	/	0.51	1.68	0.93	/	8.94	9.72	9.17	9.88	/	/	/	6.30	17.20	17.42	/	
	mm	152.0	152.0	/	13.0	42.7	23.5	/	227.0	247.0	233.0	251.0	/	/	/	160.0	7.8	7.9	/	
1-1/2	Inch	6.77	6.77	12.01	0.51	1.92	1.12	1.12	10.08	10.83	10.39	11.34	11.02	12.20	6.30	8.66	24.25	28.66	62.39	
	mm	172.0	172.0	305.0	13.0	48.8	28.5	28.5	256.0	275.0	264.0	288.0	280.0	310.0	160.0	220.0	11.0	13.0	28.3	
2	Inch	8.66	8.66	14.49	0.65	2.41	1.44	1.44	11.93	13.07	11.81	12.60	13.19	14.57	10.24	8.66	45.19	39.68	104.94	
	mm	220.0	220.0	368.0	16.5	61.2	36.5	36.5	303.0	332.0	300.0	320.0	335.0	370.0	260.0	220.0	20.5	18.0	47.6	

Piston Check Valve Standard Port

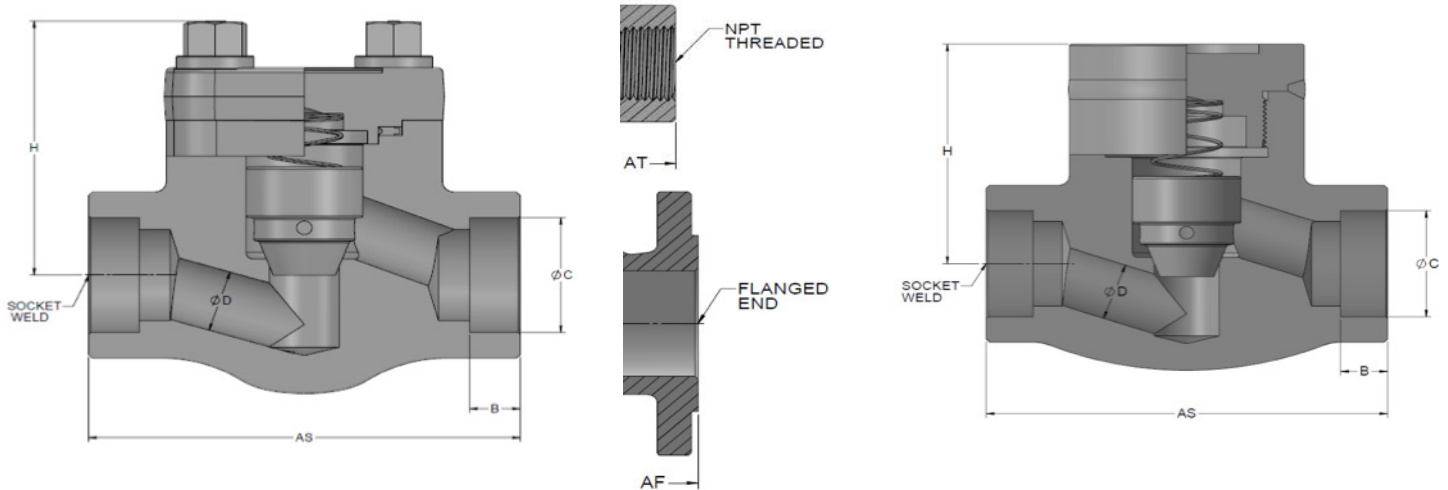

503 Series: Bolted Bonnet

507 Series: Welded Bonnet

STANDARDS				
DESIGN:	API 602	TESTING:	API 598	
	ASME B16.34		CONNECTIONS:	NPT - ASME B1.20.1
	FACE-TO-FACE - ASME B16.10			SW - ASME B16.11
PRESSURE CLASS:	NPT, SW & BW - 800, 1500		BW- ASME B16.25	
	FLANGED - 150, 300, 600, 1500		FLANGED - ASME B16.5	

DIMENSIONS														WGT.(lb/kg)										
SIZE		AT/AS 800	AF - 150	AF - 300	AF - 600	B (Min)	C (Min)	D (Min)- NPT/ SW	D (Min)- RF	H-NPT/ SW (503)	H-NPT/ SW (507)	H-RF (150)	H-RF (300)	H-RF (600)	150 (503)	150 (507)	300 (503)	300 (507)	600 (503)	600 (507)	800 (503)	800 (507)		
1/4	Inch	3.11	/	/	/	0.39	0.56	0.27	/	2.28	1.97	/	/	/	/	/	/	/	/	/	/	/	3.31	2.87
	mm	79.0	/	/	/	10.0	14.2	6.8	/	58.0	50.0	/	/	/	/	/	/	/	/	/	/	/	1.5	1.3
3/8	Inch	3.11	/	/	/	0.39	0.69	0.27	/	2.28	1.97	/	/	/	/	/	/	/	/	/	/	/	3.31	2.87
	mm	79.0	/	/	/	10.0	17.6	6.8	/	58.0	50.0	/	/	/	/	/	/	/	/	/	/	/	1.5	1.3
1/2	Inch	3.11	4.25	5.98	6.50	0.39	0.86	0.37	0.37	2.28	1.97	2.20	2.20	2.28	4.85	7.94	6.17	8.16	7.05	8.82	3.09	2.65	3.09	2.65
	mm	79.0	108.0	152.0	165.0	10.0	21.8	9.5	9.5	58.0	50.0	56.0	56.0	58.0	2.2	3.6	2.8	3.7	3.2	4.0	1.4	1.2	1.4	1.2
3/4	Inch	3.62	4.61	7.01	7.48	0.51	1.07	0.49	0.49	2.28	2.05	2.20	2.28	2.28	5.95	10.14	9.26	10.58	9.92	12.79	3.31	3.31	3.31	3.31
	mm	92.0	117.0	178.0	190.0	13.0	27.2	12.5	12.5	58.0	52.0	56.0	58.0	58.0	2.7	4.6	4.2	4.8	4.5	5.8	1.5	1.5	1.5	1.5
1	Inch	4.37	5.00	7.99	8.50	0.51	1.33	0.69	0.69	2.95	2.76	2.95	2.95	2.95	9.70	18.74	13.89	19.40	15.21	20.94	5.95	5.73	5.95	5.73
	mm	111.0	127.0	203.0	216.0	13.0	33.9	17.5	17.5	75.0	70.0	75.0	75.0	75.0	4.4	8.5	6.3	8.8	6.9	9.5	2.7	2.6	2.7	2.6
1-1/4	Inch	4.72	5.51	8.50	9.02	0.51	1.68	0.93	0.93	3.35	3.23	3.35	3.35	3.35	14.33	20.28	17.86	21.16	22.93	22.93	8.60	9.26	8.60	9.26
	mm	120.0	140.0	216.0	229.0	13.0	42.7	23.5	23.5	85.0	82.0	85.0	85.0	85.0	6.5	9.2	8.1	9.6	10.4	10.4	3.9	4.2	3.9	4.2
1-1/2	Inch	5.98	6.50	9.02	9.49	0.51	1.92	1.12	1.12	3.82	3.78	3.82	3.82	3.82	17.64	27.56	25.79	30.20	28.66	34.39	11.68	12.35	11.68	12.35
	mm	152.0	165.0	229.0	241.0	13.0	48.8	28.5	28.5	97.0	96.0	97.0	97.0	97.0	8.0	12.5	11.7	13.7	13.0	15.6	5.3	5.6	5.3	5.6
2	Inch	6.77	7.99	10.51	11.50	0.65	2.41	1.44	1.44	4.25	4.33	4.65	4.65	4.53	30.42	32.63	38.58	39.24	43.65	54.01	17.20	20.50	17.20	20.50
	mm	172.0	203.0	267.0	292.0	16.5	61.2	36.5	36.5	108.0	110.0	118.0	118.0	115.0	13.8	14.8	17.5	17.8	19.8	24.5	7.8	9.3	7.8	9.3

DIMENSIONS-1500												WGT.(lb/kg)			
SIZE		AT/AS (503)	AT/AS (507)	AF (503)	B (Min)	C (Min)	D (Min)	D (Min)	H-NPT/SW (503)	H-NPT/SW (507)	H-RF (503)	NPT/SW (503)	NPT/SW(507)	RF (503)	
1/2	Inch	4.37	4.37	8.50	0.39	0.86	0.37	0.37	2.95	2.76	2.95	6.39	6.61	13.89	
	mm	111.0	111.0	216.0	10.0	21.8	9.5	9.5	75.0	70.0	75.0	2.9	3.0	6.3	
3/4	Inch	4.37	4.37	9.02	0.51	1.07	0.49	0.49	2.95	2.76	2.95	6.17	6.39	18.96	
	mm	111.0	111.0	229.0	13.0	27.2	12.5	12.5	75.0	70.0	75.0	2.8	2.9	8.6	
1	Inch	4.72	4.72	10.00	0.51	1.33	0.69	0.69	3.35	3.23	3.35	9.04	11.24	28.66	
	mm	120.0	120.0	254.0	13.0	33.9	17.5	17.5	85.0	82.0	85.0	4.1	5.1	13.0	
1-1/4	Inch	5.98	5.98	/	0.51	1.68	0.93	0.93	3.82	3.78	/	12.79	13.45	/	
	mm	152.0	152.0	/	13.0	42.7	23.5	23.5	97.0	96.0	/	5.8	6.1	/	
1-1/2	Inch	6.77	6.77	12.01	0.51	1.92	1.12	1.12	4.25	4.33	5.31	19.40	23.81	56.66	
	mm	172.0	172.0	305.0	13.0	48.8	28.5	28.5	108.0	110.0	135.0	8.8	10.8	25.7	
2	Inch	8.66	8.66	14.49	0.65	2.41	1.44	1.44	5.20	4.53	6.50	36.38	33.51	94.58	
	mm	220.0	220.0	368.0	16.5	61.2	36.5	36.5	132.0	115.0	165.0	16.5	15.2	42.9	

Swing Check Valve Standard

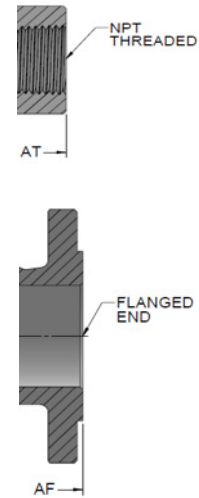
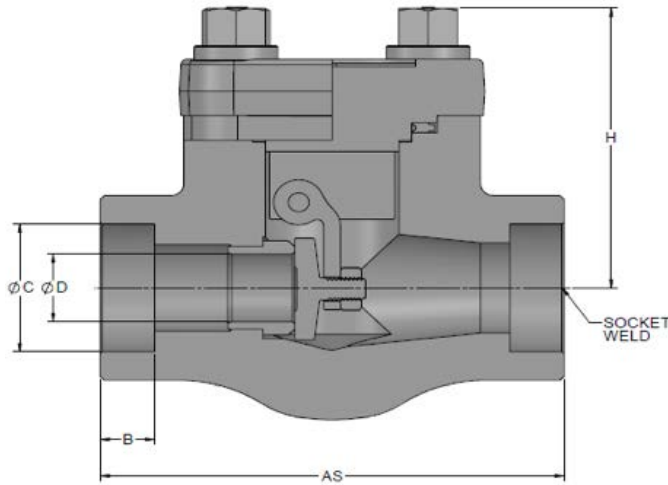

504 Series: Bolted Bonnet

STANDARDS				
DESIGN:	API 602	TESTING:	API 598	
	MSS SP-118		CONNECTIONS:	NPT - ASME B1.20.1
	ASME B16.34			SW - ASME B16.11
	FACE TO FACE-ASME B16.10			BW- ASME B16.25
PRESSURE CLASS:	NPT, SW & BW - 800, 1500	FLANGED - ASME B16.5		
	FLANGED - 150, 300, 600, 1500			

DIMENSIONS														WGT.(lb/kg)					
SIZE		AT/AS 800	AF - 150	AF - 300	AF - 600	B (Min)	C (Min)	D(Min)- NPT/SW	D(Min)-RF 150	D(Min)-RF 300/600	H-NPT/ SW(504)	H-RF(150)	H-RF(300)	H-RF(600)	150 (504)	300 (504)	600 (504)	800 (504)	
1/4	Inch	3.11	/	/	/	0.39	0.56	0.30	/	/	2.28	/	/	/	/	/	/	/	3.09
	mm	79.0	/	/	/	10.0	14.2	7.5	/	/	58.0	/	/	/	/	/	/	/	1.4
3/8	Inch	3.11	/	/	/	0.39	0.69	0.39	/	/	2.28	/	/	/	/	/	/	/	3.09
	mm	79.0	/	/	/	10.0	17.6	10	/	/	58.0	/	/	/	/	/	/	/	1.4
1/2	Inch	3.11	4.25	5.98	6.50	0.39	0.86	0.51	0.39	0.39	2.28	2.20	2.20	2.28	4.41	6.17	7.05	2.87	
	mm	79.0	108.0	152.0	165.0	10.0	21.8	13.0	10.0	10.0	58.0	56.0	56.0	58.0	2.0	2.8	3.2	1.3	
3/4	Inch	3.62	4.61	7.01	7.48	0.51	1.07	0.51	0.49	0.51	2.28	2.20	2.28	2.28	5.73	8.82	9.48	3.31	
	mm	92.0	117.0	178.0	190.0	13.0	27.2	13.0	12.5	13.0	58.0	56.0	58.0	58.0	2.6	4.0	4.3	1.5	
1	Inch	4.37	5.00	8.50	8.50	0.51	1.33	0.71	0.71	0.71	2.95	2.95	2.95	2.95	9.26	13.45	14.33	5.95	
	mm	111.0	127.0	216.0	216.0	13.0	33.9	18.0	18.0	18.0	75.0	75.0	75.0	75.0	4.2	6.1	6.5	2.7	
1-1/4	Inch	4.72	5.51	9.02	9.02	0.51	1.68	0.94	0.94	0.94	3.27	3.27	3.27	3.27	13.45	17.64	18.74	8.16	
	mm	120.0	140.0	229.0	229.0	13.0	42.7	24.0	24.0	24.0	83.0	83.0	83.0	83.0	6.1	8.0	8.5	3.7	
1-1/2	Inch	4.72	6.50	9.49	9.49	0.51	1.92	1.14	1.14	1.14	3.70	3.70	3.82	3.82	16.31	24.25	27.12	9.70	
	mm	120.0	165.0	241.0	241.0	13.0	48.8	29.0	29.0	29.0	94.0	94.0	97.0	97.0	7.4	11.0	12.3	4.4	
2	Inch	5.51	7.99	10.51	11.50	0.65	2.41	1.44	1.44	1.44	4.21	4.49	4.53	4.53	28.66	35.49	38.80	14.33	
	mm	140.0	203.0	267.0	292.0	16.5	61.2	36.5	36.5	36.5	107.0	114.0	115.0	115.0	13.0	16.1	17.6	6.5	

DIMENSIONS-1500											WGT.(lb/kg)	
SIZE		AT/AS (504)	AF (504)	B (Min)	C (Min)	D (Min)-NPT/SW	D (Min)-RF (504)	H -NPT/SW (504)	H-RF (504)	RF (504)	NPT/SW (504)	
1/2	Inch	4.37	8.50	0.39	0.86	0.51	0.39	2.95	2.95	13.23	6.17	
	mm	111.0	216.0	10.0	21.8	13.0	10.0	75.0	75.0	6.0	2.8	
3/4	Inch	4.37	9.02	0.51	1.07	0.51	0.51	2.95	2.95	16.53	5.95	
	mm	111.0	229.0	13.0	27.2	13.0	13.0	75.0	75.0	7.5	2.7	
1	Inch	4.72	10.00	0.51	1.33	0.71	0.71	3.27	3.27	26.01	9.04	
	mm	120.0	254.0	13.0	33.9	18.0	18.0	83.0	83.0	11.8	4.1	
1-1/4	Inch	4.72	/	0.51	1.68	0.94	/	3.70	/	/	10.58	
	mm	120.0	/	13.0	42.7	24.0	/	94.0	/	/	4.8	
1-1/2	Inch	5.51	12.01	0.51	1.92	1.14	1.14	4.21	5.31	52.91	16.09	
	mm	140.0	305.0	13.0	48.8	29.0	29.0	107.0	135.0	24.0	7.3	
2	Inch	6.30	14.49	0.65	2.41	1.44	1.44	5.12	6.50	89.95	26.90	
	mm	160.0	368.0	16.5	61.2	36.5	36.5	130.0	165.0	40.8	12.2	

Gate Valve Full Port

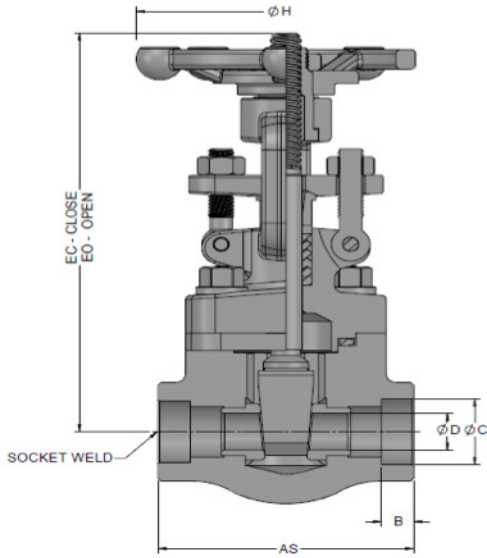

511 Series: Bolted Bonnet

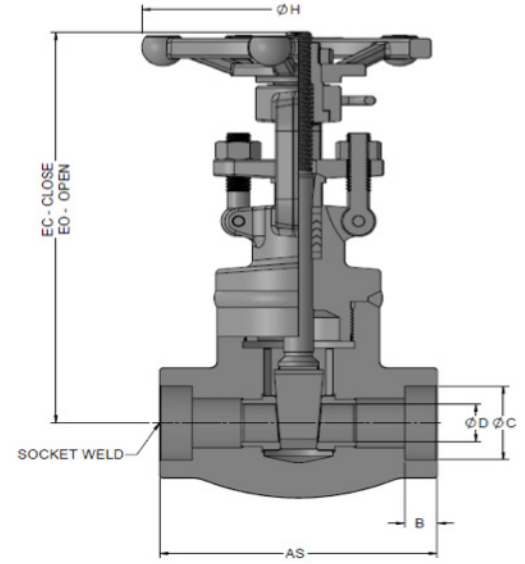
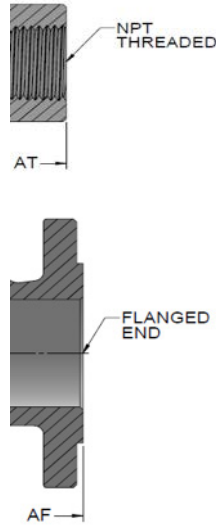

515 Series: Welded Bonnet

STANDARDS				
DESIGN:	API 602	TESTING:	API 598	
	ASME B16.34		CONNECTIONS:	NPT - ASME B1.20.1
	FACE-TO-FACE - ASME B16.10			SW - ASME B16.11
PRESSURE CLASS:	NPT, SW & BW - 800, 1500	BW- ASME B16.25		
	FLANGED - 150, 300, 600, 1500	FLANGED - ASME B16.5		

SIZE		DIMENSIONS														WGT.(lb./kg)										
		AT/AS [511]	AT/AS [515]	AF-150 [511]	AF-300 [511]	AF-600 [511]	B [Min]	C [Min]	D [Min] NPT/SW	D [Min] RF	EC-NPT/SW [511]	EO-NPT/SW [511]	EC-NPT/SW [515]	EO-NPT/SW [515]	EC RF [511]	EO RF [511]	H	150 [511]	150 [515]	300 [511]	300 [515]	600 [511]	600 [515]	800 [511]	800 [515]	
1/4	Inch	3.11	3.11	/	/	/	0.39	0.56	0.30	/	5.51	6.18	5.51	6.38	/	/	3.94	/	/	/	/	/	/	/	4.85	4.19
	mm	79.0	79.0	/	/	/	10.0	14.2	7.5	/	140.0	157.0	140.0	162.0	/	/	100.0	/	/	/	/	/	/	/	2.2	1.9
3/8	Inch	3.11	3.11	/	/	/	0.39	0.69	0.39	/	5.51	6.18	5.51	6.38	/	/	3.94	/	/	/	/	/	/	/	4.63	3.97
	mm	79.0	79.0	/	/	/	10.0	17.6	10	/	140.0	157.0	140.0	162.0	/	/	100.0	/	/	/	/	/	/	/	2.1	1.8
1/2	Inch	3.11	3.11	4.25	5.51	6.50	0.39	0.86	0.51	0.51	5.59	6.18	5.63	6.22	5.59	6.18	3.94	8.77	8.82	10.78	10.36	12.79	11.68	4.41	3.75	
	mm	79.0	79.0	108.0	140.0	165.0	10.0	21.8	13.0	13.0	142.0	157.0	143.0	158.0	142.0	157.0	100.0	4.0	4.0	4.9	4.7	5.8	5.3	2.0	1.7	
3/4	Inch	4.37	4.37	4.61	5.98	7.48	0.51	1.07	0.71	0.71	6.50	7.28	7.01	7.80	6.50	7.28	4.72	13.49	13.23	15.94	15.43	19.40	17.64	8.16	8.38	
	mm	111.0	111.0	117.0	152.0	190.0	13.0	27.2	18.0	18.0	165.0	185.0	178.0	198.0	165.0	185.0	120.0	6.1	6.0	7.2	7.0	8.8	8.0	3.7	3.8	
1	Inch	4.72	4.72	5.00	6.50	8.50	0.51	1.33	0.94	0.94	7.87	8.90	8.03	9.06	7.87	8.90	6.30	19.93	18.96	23.26	22.27	29.50	27.78	12.57	12.35	
	mm	120.0	120.0	127.0	165.0	216.0	13.0	33.9	24.0	24.0	200.0	226.0	204.0	230.0	200.0	226.0	160.0	9.0	8.6	10.6	10.1	13.4	12.6	5.7	5.6	
1-1/4	Inch	4.72	4.72	5.51	7.01	9.02	0.51	1.68	1.14	1.14	8.23	9.49	8.39	9.61	8.23	9.49	6.30	22.93	22.05	27.87	26.46	34.39	33.07	14.33	14.11	
	mm	120.0	120.0	140.0	178.0	229.0	13.0	42.7	29.0	29.0	209.0	241.0	213.0	244.0	209.0	241.0	160.0	10.4	10.0	12.6	12.0	15.6	15.0	6.5	6.4	
1-1/2	Inch	5.51	5.51	6.50	7.48	9.49	0.51	1.92	1.44	1.44	9.02	10.75	9.65	11.18	9.02	10.75	8.66	34.17	32.63	39.68	38.14	42.99	41.45	21.16	22.05	
	mm	140.0	140.0	165.0	190.0	241.0	13.0	48.8	36.5	36.5	229.0	273.0	245.0	284.0	229.0	273.0	220.0	15.5	14.8	18.0	17.3	19.5	18.8	9.6	10.0	
2	Inch	6.30	7.01	7.01	8.50	11.50	0.65	2.41	1.81	1.81	11.14	13.11	11.54	13.50	11.14	13.11	8.66	47.40	45.86	52.91	28.66	56.22	31.97	34.17	30.86	
	mm	160.0	178.0	178.0	216.0	292.0	16.5	61.2	46.0	46.0	283.0	333.0	293.0	343.0	283.0	333.0	220.0	21.5	20.8	24.0	13.0	25.5	14.5	15.5	14.0	

SIZE		DIMENSIONS-1500											WGT.(lb./kg)	
		AT/AS [511]	AT/AS [515]	B [Min]	C [Min]	D [Min] NPT/SW	EC-NPT/SW [511]	EO-NPT/SW [511]	EC-NPT/SW [515]	EO-NPT/SW [515]	H-NPT/SW	NPT/SW [511]	NPT/SW [515]	
1/2	Inch	4.37	4.37	0.39	0.86	0.51	6.50	7.28	7.01	7.72	4.72	8.38	8.60	
	mm	111.0	111.0	10.0	21.8	13.0	165.0	185.0	178.0	196.0	120.0	3.8	3.9	
3/4	Inch	4.72	4.72	0.51	1.07	0.71	7.87	8.66	8.03	8.86	6.30	13.23	13.23	
	mm	120.0	120.0	13.0	27.2	18.0	200.0	220.0	204.0	225.0	160.0	6.0	6.0	
1	Inch	4.72	4.72	0.51	1.33	0.94	8.23	9.25	8.39	9.41	6.30	15.21	14.55	
	mm	120.0	120.0	13.0	33.9	24.0	209.0	235.0	213.0	239.0	160.0	6.9	6.6	
1-1/4	Inch	5.51	5.51	0.51	1.68	1.14	9.02	10.24	9.65	10.98	8.66	21.83	24.25	
	mm	140.0	140.0	13.0	42.7	29.0	229.0	260.0	245.0	279.0	220.0	9.9	11.0	
1-1/2	Inch	6.30	7.01	0.51	1.92	1.44	11.14	12.68	11.02	12.56	8.66	36.16	33.73	
	mm	160.0	178.0	13.0	48.8	36.5	283.0	322.0	280.0	319.0	220.0	16.4	15.3	
2	Inch	7.01	7.01	0.65	2.41	1.81	11.14	13.27	11.02	12.99	8.66	40.79	33.07	
	mm	178.0	178.0	16.5	61.2	46.0	283.0	337.0	280.0	330.0	220.0	18.5	15.0	

Globe Valve Full Port

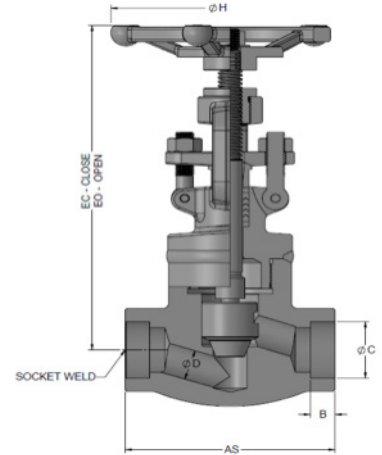
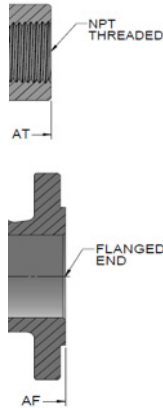
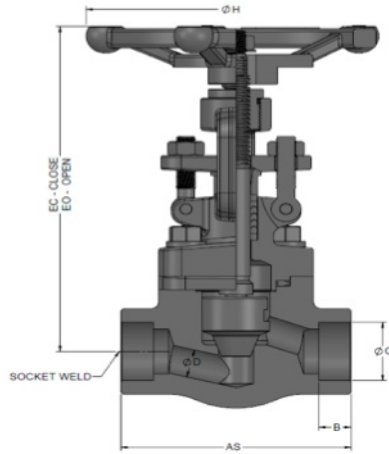

522 Series: Bolted Bonnet

516 Series: Welded Bonnet

STANDARDS				
DESIGN:	API 602	TESTING:	API 598	
	MSS SP-118		CONNECTIONS:	NPT - ASME B1.20.1
	ASME B16.34			SW - ASME B16.11
	FACE TO FACE-ASME B16.10			BW- ASME B16.25
PRESSURE CLASS:	NPT, SW & BW - 800, 1500	FLANGED - ASME B16.5		
	FLANGED - 150, 300, 600, 1500			

DIMENSIONS																WGT.(lb/kg)									
SIZE		AT/AS 800	AF-150	AF-300	AF-600	B (Min)	C (Min)	D (Min) NPT/SW	D (Min) RF	EC-NPT/SW (522)	EO-NPT/SW (522)	EC-NPT/SW (516)	EO-NPT/SW (516)	EC RF (522)	EO RF (522)	H	150 (522)	150 (516)	300 (522)	300 (516)	600 (522)	600 (516)	800 (522)	800 (516)	
1/4	Inch	3.62	/	/	/	0.39	0.56	0.27	/	5.87	6.34	6.10	6.65	/	/	3.94	/	/	/	/	/	/	/	5.07	5.73
	mm	92.0	/	/	/	10.0	14.2	6.8	/	149.0	161.0	155.0	169.0	/	/	100.0	/	/	/	/	/	/	/	2.3	2.6
3/8	Inch	3.62	/	/	/	0.39	0.69	0.37	/	5.87	6.34	6.10	6.65	/	/	3.94	/	/	/	/	/	/	/	4.85	5.51
	mm	92.0	/	/	/	10.0	17.6	9.5	/	149.0	161.0	155.0	169.0	/	/	100.0	/	/	/	/	/	/	/	2.2	2.5
1/2	Inch	3.62	4.25	5.98	6.50	0.39	0.86	0.49	0.49	5.87	6.34	6.10	6.65	5.87	6.34	3.94	8.82	8.82	11.24	11.02	17.20	16.53	5.07	4.41	
	mm	92.0	108.0	152.0	165.0	10.0	21.8	12.5	12.5	149.0	161.0	155.0	169.0	149.0	161.0	100.0	4.0	4.0	5.1	5.0	7.8	7.5	2.3	2.0	
3/4	Inch	4.37	4.61	7.01	7.48	0.51	1.07	0.69	0.69	6.97	7.60	7.60	8.07	6.97	7.60	4.72	13.65	13.45	15.87	15.43	27.56	27.34	8.38	8.60	
	mm	111.0	117.0	178.0	190.0	13.0	27.2	17.5	17.5	177.0	193.0	193.0	205.0	177.0	193.0	120.0	6.2	6.1	7.2	7.0	12.5	12.4	3.8	3.9	
1	Inch	4.72	5.00	7.99	8.50	0.51	1.33	0.89	0.89	8.35	9.06	8.66	9.41	8.35	9.06	6.30	21.16	20.72	25.35	24.25	37.48	37.04	13.01	13.01	
	mm	120.0	127.0	203.0	216.0	13.0	33.9	22.5	22.5	212.0	230.0	220.0	239.0	212.0	230.0	160.0	9.6	9.4	11.5	11.0	17.0	16.8	5.9	5.9	
1-1/4	Inch	5.98	5.51	8.50	9.02	0.51	1.68	1.12	1.12	8.82	9.76	9.13	9.88	8.82	9.76	6.30	23.15	22.05	29.76	28.66	51.81	50.71	16.75	16.75	
	mm	152.0	140.0	216.0	229.0	13.0	42.7	28.5	28.5	224.0	248.0	232.0	251.0	224.0	248.0	160.0	10.5	10.0	13.5	13.0	23.5	23.0	7.6	7.6	
1-1/2	Inch	6.77	6.50	9.02	9.49	0.51	1.92	1.40	1.40	9.92	11.10	10.55	11.42	9.92	11.10	8.66	37.48	36.38	43.43	41.89	85.54	84.88	22.71	26.46	
	mm	172.0	165.0	229.0	241.0	13.0	48.8	35.5	35.5	252.0	282.0	268.0	290.0	252.0	282.0	220.0	17.0	16.5	19.7	19.0	38.8	38.5	10.3	12.0	
2	Inch	8.66	7.99	10.51	11.50	0.65	2.41	1.75	1.75	12.44	13.66	11.77	12.87	12.44	13.66	8.66	48.50	48.50	54.45	52.91	96.56	94.80	49.38	38.58	
	mm	220.0	203.0	267.0	292.0	16.5	61.2	44.5	44.5	316.0	347.0	299.0	327.0	316.0	347.0	220.0	22.0	22.0	24.7	24.0	43.8	43.0	22.4	17.5	

DIMENSIONS-1500												WGT.(lb/kg)	
SIZE		AT/AS (522)	AT/AS (516)	B (Min)	C (Min)	D-NPT/SW (Min)	EC-NPT/SW(522)	EO-NPT/SW(522)	EC-NPT/SW(516)	EO-NPT/SW(516)	H	NPT/SW (522)	NPT/SW (516)
1/2	Inch	4.37	4.37	0.39	0.86	0.37	6.97	7.60	7.60	8.07	4.72	8.82	8.82
	mm	111.0	111.0	10.0	21.8	9.5	177.0	193.0	193.0	205.0	120.0	4.0	4.0
3/4	Inch	4.72	4.72	0.51	1.07	0.59	8.46	9.06	8.58	9.41	6.30	13.23	13.45
	mm	120.0	120.0	13.0	27.2	15.0	215.0	230.0	218.0	239.0	160.0	6.0	6.1
1	Inch	5.98	5.98	0.51	1.33	0.79	8.94	9.76	9.13	9.88	6.30	17.20	17.42
	mm	152.0	152.0	13.0	33.9	20.0	227.0	248.0	232.0	251.0	160.0	7.8	7.9
1-1/4	Inch	6.77	6.77	0.51	1.68	1.02	10.16	11.10	10.55	11.42	8.66	24.69	27.12
	mm	172.0	172.0	13.0	42.7	26.0	258.0	282.0	268.0	290.0	220.0	11.2	12.3
1-1/2	Inch	6.77	6.77	0.51	1.92	1.12	10.16	11.10	10.55	11.42	8.66	24.25	27.12
	mm	172.0	172.0	13.0	48.8	28.5	258.0	282.0	268.0	290.0	220.0	11.0	12.3
2	Inch	8.66	8.66	0.65	2.41	1.44	11.93	13.07	11.77	12.87	8.66	45.19	39.68
	mm	220.0	220.0	16.5	61.2	36.5	303.0	332.0	299.0	327.0	220.0	20.5	18.0

Piston Check Valve Full Port

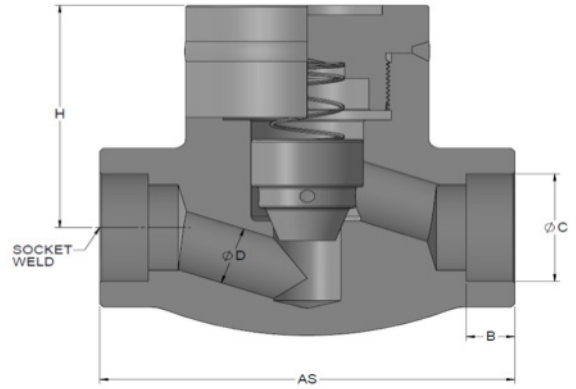
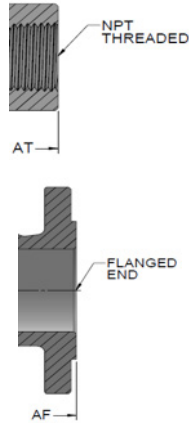
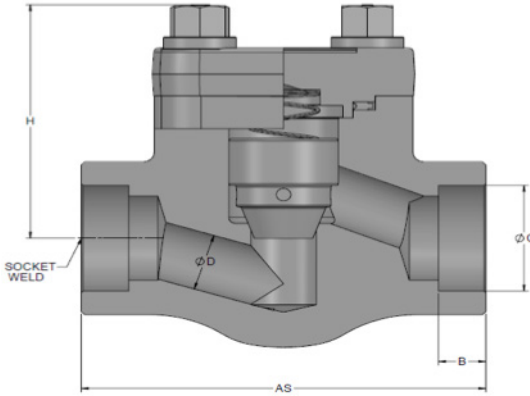

523 Series: Bolted Bonnet

517 Series: Welded Bonnet

STANDARDS				
DESIGN:	API 602	TESTING:	API 598	
	MSS SP-118		CONNECTIONS:	NPT - ASME B1.20.1
	ASME B16.34			SW - ASME B16.11
PRESSURE CLASS:	FACE TO FACE-ASME B16.10	BW- ASME B16.25	FLANGED - ASME B16.5	
	NPT, SW & BW - 800, 1500			
	SW & BW - 1500			
	FLANGED - 150, 300, 600, 1500			

DIMENSIONS											WGWT.(lb/kg)									
SIZE		AT/AS 800	AF - 150	AF - 300	AF - 600	B (Min)	C (Min)	D(Min)- NPT/SW	D(Min)-RF	H-RF/ NPT/SW (523)	H-RF/ NPT/SW (517)	150 (523)	150 (517)	300 (523)	300 (517)	600 (523)	600 (517)	800 (523)	800 (517)	
1/4	Inch	3.62	/	/	/	0.39	0.56	0.27	/	2.40	2.05	/	/	/	/	/	/	/	3.97	3.75
	mm	92.0	/	/	/	10.0	14.2	6.8	/	61.0	52.0	/	/	/	/	/	/	/	1.8	1.7
3/8	Inch	3.62	/	/	/	0.39	0.69	0.37	/	2.40	2.05	/	/	/	/	/	/	/	3.97	3.75
	mm	92.0	/	/	/	10.0	17.6	9.5	/	61.0	52.0	/	/	/	/	/	/	/	1.8	1.7
1/2	Inch	3.62	4.25	5.98	6.50	0.39	0.86	0.49	0.49	2.28	2.05	10.14	9.92	10.58	10.36	12.79	12.35	3.31	3.53	
	mm	92.0	108.0	152.0	165.0	10.0	21.8	12.5	12.5	58.0	52.0	4.6	4.5	4.8	4.7	5.8	5.6	1.5	1.6	
3/4	Inch	4.37	4.61	7.01	7.48	0.51	1.07	0.69	0.69	2.95	2.76	18.74	18.30	19.40	19.40	20.94	20.72	8.38	7.05	
	mm	111.0	117.0	178.0	190.0	13.0	27.2	17.5	17.5	75.0	70.0	8.5	8.3	8.8	8.8	9.5	9.4	3.8	3.2	
1	Inch	4.72	5.00	7.99	8.50	0.51	1.33	0.89	0.89	3.35	3.23	20.28	19.84	21.16	20.94	22.93	22.93	13.01	11.68	
	mm	120.0	127.0	203.0	216.0	13.0	33.9	22.5	22.5	85.0	82.0	9.2	9.0	9.6	9.5	10.4	10.4	5.9	5.3	
1-1/4	Inch	5.98	5.51	8.50	9.02	0.51	1.68	1.12	1.12	3.82	3.74	27.56	26.46	30.20	29.76	34.39	34.83	16.75	15.43	
	mm	152.0	140.0	216.0	229.0	13.0	42.7	28.5	28.5	97.0	95.0	12.5	12.0	13.7	13.5	15.6	15.8	7.6	7.0	
1-1/2	Inch	6.77	6.50	9.02	9.49	0.51	1.92	1.40	1.40	4.25	4.33	32.63	31.97	39.24	37.48	54.01	52.91	22.71	22.05	
	mm	172.0	165.0	229.0	241.0	13.0	48.8	35.5	35.5	108.0	110.0	14.8	14.5	17.8	17.0	24.5	24.0	10.3	10.0	
2	Inch	8.66	7.99	10.51	11.50	0.65	2.41	1.75	1.75	5.71	4.53	37.04	35.27	43.65	41.89	58.42	57.32	38.14	34.83	
	mm	220.0	203.0	267.0	292.0	16.5	61.2	44.5	44.5	145.0	115.0	16.8	16.0	19.8	19.0	26.5	26.0	17.3	15.8	

DIMENSIONS-1500								WGWT.(lb/kg)		
SIZE		AS/AT (523)	AS/AT (517)	B (Min)	C (Min)	D-NPT/SW (Min)	H-NPT/SW (523)	H-NPT/SW (517)	NPT/SW (523)	NPT/SW (517)
1/2	Inch	4.37	4.37	0.39	0.86	0.37	2.95	2.76	6.39	7.05
	mm	111.0	111.0	10.0	21.8	9.5	75.0	70.0	2.9	3.2
3/4	Inch	4.72	4.72	0.51	1.07	0.59	3.35	3.23	9.26	11.68
	mm	120.0	120.0	13.0	27.2	15.0	85.0	82.0	4.2	5.3
1	Inch	5.98	5.98	0.51	1.33	0.79	3.82	3.74	13.01	15.87
	mm	152.0	152.0	13.0	33.9	20.0	97.0	95.0	5.9	7.2
1-1/4	Inch	6.77	6.77	0.51	1.68	1.02	4.25	4.33	19.62	23.59
	mm	172.0	172.0	13.0	42.7	26.0	108.0	110.0	8.9	10.7
1-1/2	Inch	6.77	6.77	0.51	1.92	1.12	4.25	4.33	19.40	23.59
	mm	172.0	172.0	13.0	48.8	28.5	108.0	110.0	8.8	10.7
2	Inch	8.66	8.66	0.65	2.41	1.38	5.20	4.53	36.38	34.83
	mm	220.0	220.0	16.5	61.2	35.0	132.0	115.0	16.5	15.8

Swing Check Valve Full Port

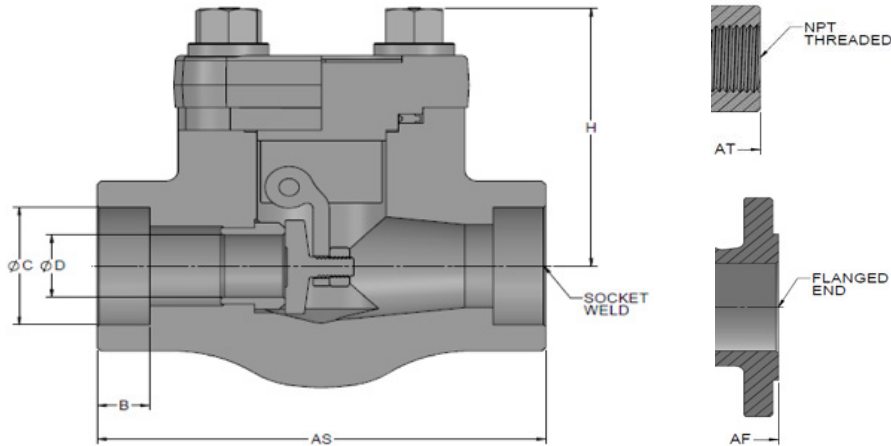

514 Series: Bolted Bonnet

STANDARDS				
DESIGN:	API 602	TESTING:	API 598	
	MSS SP-118		CONNECTIONS:	NPT - ASME B1.20.1
	ASME B16.34			SW - ASME B16.11
	FACE TO FACE-ASME B16.10			BW- ASME B16.25
PRESSURE CLASS:	NPT, SW & BW - 800, 1500		FLANGED - ASME B16.5	
	FLANGED - 150, 300, 600, 1500			

DIMENSIONS											WGT.(lb/kg)			
SIZE		AT/AS 800	AF-150	AF-300	AF-600	B [Min]	C [Min]	D[Min]-NPT/ SW	D[Min]-RF	H	150 [514]	300 [514]	600 [514]	800 [514]
1/4	Inch	3.11	/	/	/	0.39	0.56	0.30	/	2.40	/	/	/	3.97
	mm	79.0	/	/	/	10.0	14.2	7.5	/	61.0	/	/	/	1.8
3/8	Inch	3.11	/	/	/	0.39	0.69	0.39	/	2.40	/	/	/	3.97
	mm	79.0	/	/	/	10.0	17.6	10	/	61.0	/	/	/	1.8
1/2	Inch	3.11	4.25	5.98	6.50	0.39	0.86	0.51	0.51	2.28	10.14	10.58	12.79	2.87
	mm	79.0	108.0	152.0	165.0	10.0	21.8	13.0	13.0	58.0	4.6	4.8	5.8	1.3
3/4	Inch	4.37	4.61	7.01	7.48	0.51	1.07	0.71	0.71	2.95	18.74	19.40	20.94	5.95
	mm	111.0	117.0	178.0	190.0	13.0	27.2	18.0	18.0	75.0	8.5	8.8	9.5	2.7
1	Inch	4.72	5.00	8.50	8.50	0.51	1.33	0.94	0.94	3.27	20.28	21.16	22.93	8.16
	mm	120.0	127.0	216.0	216.0	13.0	33.9	24.0	24.0	83.0	9.2	9.6	10.4	3.7
1-1/4	Inch	4.72	5.51	9.02	9.02	0.51	1.68	1.14	1.14	3.70	27.56	30.20	34.39	9.70
	mm	120.0	140.0	229.0	229.0	13.0	42.7	29.0	29.0	94.0	12.5	13.7	15.6	4.4
1-1/2	Inch	5.51	6.50	9.49	9.49	0.51	1.92	1.44	1.44	4.21	32.63	39.24	54.01	14.33
	mm	140.0	165.0	241.0	241.0	13.0	48.8	36.5	36.5	107.0	14.8	17.8	24.5	6.5
2	Inch	6.30	7.99	10.51	11.50	0.65	2.41	1.81	1.81	5.12	42.77	59.30	74.07	28.66
	mm	160.0	203.0	267.0	292.0	16.5	61.2	46.0	46.0	130.0	19.4	26.9	33.6	13.0

DIMENSIONS-1500							WGT.(lb/kg)
SIZE		AT/AS [514]	B [Min]	C [Min]	D [Min]-NPT/SW	H	NPT/SW [514]
1/2	Inch	4.37	0.39	0.86	0.51	2.95	6.39
	mm	111.0	10.0	21.8	13.0	75.0	2.9
3/4	Inch	4.72	0.51	1.07	0.71	3.27	8.82
	mm	120.0	13.0	27.2	18.0	83.0	4.0
1	Inch	4.72	0.51	1.33	0.94	3.70	10.14
	mm	120.0	13.0	33.9	24.0	94.0	4.6
1-1/4	Inch	5.51	0.51	1.68	1.14	4.21	14.99
	mm	140.0	13.0	42.7	29.0	107.0	6.8
1-1/2	Inch	6.30	0.51	1.92	1.44	5.12	26.01
	mm	160.0	13.0	48.8	36.5	130.0	11.8
2	Inch	7.01	0.65	2.41	1.81	5.51	28.22
	mm	178.0	16.5	61.2	46.0	140.0	12.8

Y-Pattern Globe Valve Standard Port

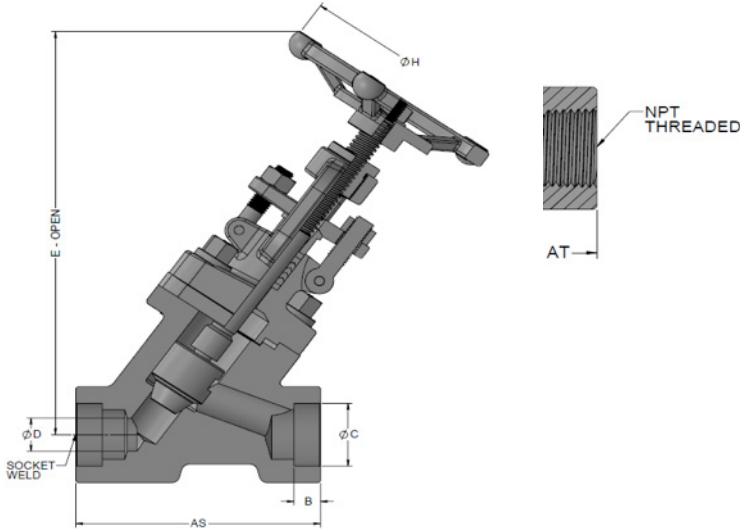

509 Series: Bolted Bonnet

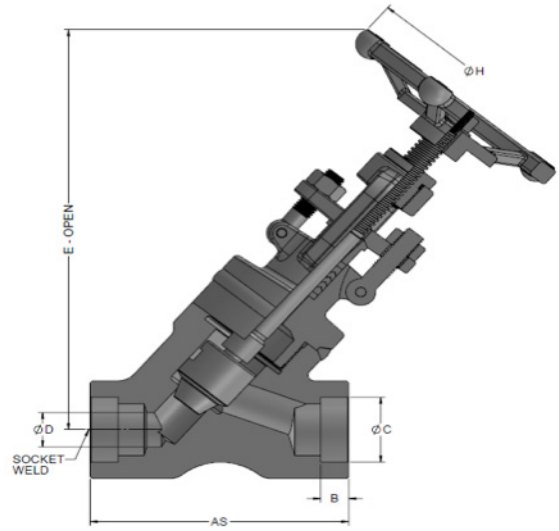

512 Series: Welded Bonnet

STANDARDS			
DESIGN:	API 602	CONNECTIONS:	NPT - ASME B1.20.1
	MSS SP-118		SW - ASME B16.11
	ASME B16.34		BW- ASME B16.25
TESTING:	API 598		
PRESSURE CLASS:	NPT, SW & BW - 800, 1500		

DIMENSIONS												WGT.(lb/kg)			
SIZE		AT/AS	509	AS/AT	512	B (Min)	C (Min)	D(Min)-NPT/ SW	EC-NPT/SW (509)	EC-NPT/SW (509)	EC-NPT/SW (512)	EC-NPT/SW (512)	H	NPT/SW (509)	NPT/SW (512)
1/4	Inch	3.86	3.74	0.39	0.56	0.27	6.77	7.17	6.50	6.77	3.94	6.17	4.41		
	mm	98.0	95.0	10.0	14.2	6.8	172.0	182.0	165.0	172.0	100.0	2.8	2.00		
3/8	Inch	3.86	3.74	0.39	0.69	0.27	6.77	7.17	6.50	6.77	3.94	6.17	4.41		
	mm	98.0	95.0	10.0	17.6	6.8	172.0	182.0	165.0	172.0	100.0	2.8	2.00		
1/2	Inch	3.86	3.74	0.39	0.86	0.37	6.77	7.17	6.50	6.77	3.94	5.95	4.19		
	mm	98.0	95.0	10.0	21.8	9.5	172.0	182.0	165.0	172.0	100.0	2.7	1.9		
3/4	Inch	3.86	4.37	0.51	1.07	0.49	6.77	7.17	6.93	7.24	3.94	5.73	5.29		
	mm	98.0	111.0	13.0	27.2	12.5	172.0	182.0	176.0	184.0	100.0	2.6	2.4		
1	Inch	4.72	4.72	0.51	1.33	0.69	8.58	9.29	8.27	8.54	4.72	10.58	9.26		
	mm	120.0	120.0	13.0	33.9	17.5	218.0	236.0	210.0	217.0	120.0	4.8	4.2		
1-1/4	Inch	5.51	5.51	0.51	1.68	0.93	9.65	10.04	10.08	10.55	6.30	14.99	14.99		
	mm	140.0	140.0	13.0	42.7	23.5	245.0	255.0	256.0	268.0	160.0	6.8	6.8		
1-1/2	Inch	5.51	5.51	0.51	1.92	1.12	10.31	10.79	10.08	10.55	6.30	18.74	18.74		
	mm	140.0	140.0	13.0	48.8	28.5	262.0	274.0	256.0	268.0	160.0	8.5	8.5		
2	Inch	6.50	7.09	0.65	2.41	1.44	13.46	13.86	11.50	12.13	8.66	30.86	24.91		
	mm	165.0	180.0	16.5	61.2	36.5	342.0	352.0	292.0	308.0	220.0	14.0	11.3		

DIMENSIONS - 1500												WGT.(lb/kg)			
SIZE		AT/AS	509	AS/AT	512	B (Min)	C (Min)	D-NPT/SW (Min)	EC-NPT/SW (509)	EC-NPT/SW (509)	EC-NPT/SW (512)	EC-NPT/SW (512)	H	NPT/SW (509)	NPT/SW (512)
1/2	Inch	4.72	4.72	0.39	0.86	0.37	8.66	8.94	7.99	8.35	4.72	11.02	9.92		
	mm	120.0	120.0	10.0	21.8	9.5	220.0	227.0	203.0	212.0	120.0	5.0	4.5		
3/4	Inch	4.72	4.72	0.51	1.07	0.49	8.66	8.94	7.99	8.35	4.72	10.80	9.70		
	mm	120.0	120.0	13.0	27.2	12.5	220.0	227.0	203.0	212.0	120.0	4.9	4.4		
1	Inch	5.51	5.51	0.51	1.33	0.69	9.84	10.31	9.76	10.12	6.30	15.65	15.65		
	mm	140.0	140.0	13.0	33.9	17.5	250.0	262.0	248.0	257.0	160.0	7.1	7.1		
1-1/4	Inch	5.51	5.51	0.51	1.68	0.93	10.51	10.98	10.12	10.87	6.30	19.62	19.40		
	mm	140.0	140.0	13.0	42.7	23.5	267.0	279.0	257.0	276.0	160.0	8.9	8.8		
1-1/2	Inch	6.50	7.09	0.51	1.92	1.12	12.20	12.80	12.05	12.76	8.66	33.07	26.68		
	mm	165.0	180.0	13.0	48.8	28.5	310.0	325.0	306.0	324.0	220.0	15.0	12.1		
2	Inch	8.66	8.86	0.65	2.41	1.44	13.58	14.37	12.48	13.19	8.66	48.50	43.21		
	mm	220.0	225.0	16.5	61.2	36.5	345.0	365.0	317.0	335.0	220.0	22.0	19.6		

Y-Pattern Globe Valve Full Port

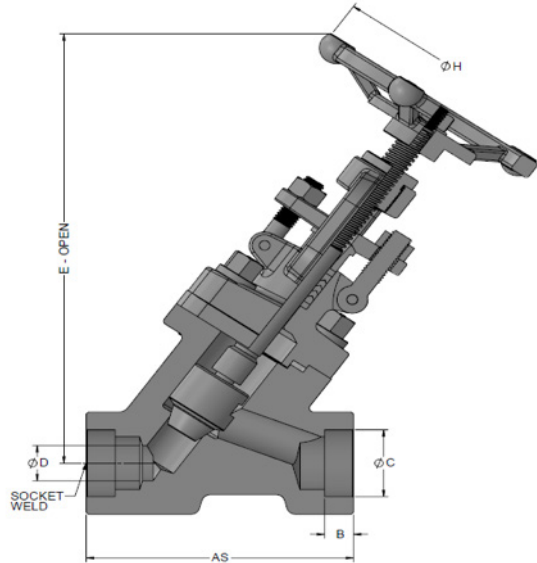

509 Series: Bolted Bonnet

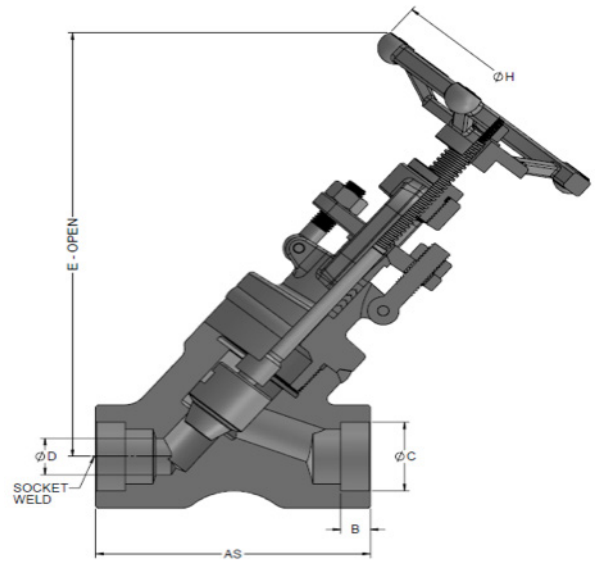

512 Series: Welded Bonnet

STANDARDS			
DESIGN:	API 602	CONNECTIONS:	NPT - ASME B1.20.1
	MSS SP-118		SW - ASME B16.11
	ASME B16.34		BW - ASME B16.25
TESTING:	API 598		
PRESSURE CLASS:	NPT, SW & BW - 800, 1500		

DIMENSIONS												WG(T,lb/kg)	
SIZE		AS/AT 509	AS/AT 512	B (Min)	C (Min)	D (Min)-NPT/SW	EC-NPT/SW (509)	EO-NPT/SW (509)	EC-NPT/SW (512)	EO-NPT/SW (512)	H	NPT/SW (509)	NPT/SW (512)
1/4	Inch	3.86	3.74	0.39	0.56	0.27	6.77	7.17	6.50	6.77	3.94	6.17	5.29
	mm	98.0	95.0	10.0	14.2	6.8	172.0	182.0	165.0	172.0	100.0	2.8	2.40
3/8	Inch	3.86	3.74	0.39	0.69	0.37	6.77	7.17	6.50	6.77	3.94	6.17	5.29
	mm	98.0	95.0	10.0	17.6	9.5	172.0	182.0	165.0	172.0	100.0	2.8	2.40
1/2	Inch	3.86	3.74	0.39	0.86	0.49	6.77	7.17	6.50	6.77	3.94	5.95	5.07
	mm	98.0	95.0	10.0	21.8	12.5	172.0	182.0	165.0	172.0	100.0	2.7	2.30
3/4	Inch	4.72	4.72	0.51	1.07	0.69	8.58	9.29	8.27	8.54	4.72	10.58	9.04
	mm	120.0	120.0	13.0	27.2	17.5	218.0	236.0	210.0	217.0	120.0	4.8	4.10
1	Inch	5.51	5.51	0.51	1.33	0.89	9.65	10.04	10.08	10.55	6.30	14.99	13.67
	mm	140.0	140.0	13.0	33.9	22.5	245.0	255.0	256.0	268.0	160.0	6.8	6.20
1-1/4	Inch	5.51	5.51	0.51	1.68	1.12	10.31	10.79	10.08	10.55	6.30	18.74	16.75
	mm	140.0	140.0	13.0	42.7	28.5	262.0	274.0	256.0	268.0	160.0	8.5	7.60
1-1/2	Inch	6.50	7.09	0.51	1.92	1.40	13.46	13.86	11.50	12.13	8.66	30.86	26.23
	mm	165.0	180.0	13.0	48.8	35.5	342.0	352.0	292.0	308.0	220.0	14.0	11.90
2	Inch	8.66	8.86	0.65	2.41	1.75	13.58	14.37	12.48	13.19	8.66	48.50	40.56
	mm	220.0	225.0	16.5	61.2	44.5	345.0	365.0	317.0	335.0	220.0	22.0	18.40

DIMENSIONS - 1500												WG(T,lb/kg)	
SIZE		AS/AT 509	AS/AT 512	B (Min)	C (Min)	D (Min)-NPT/SW	EC-NPT/SW (509)	EO-NPT/SW (509)	EC-NPT/SW (512)	EO-NPT/SW (512)	H	NPT/SW (509)	NPT/SW (512)
1/2	Inch	4.72	4.72	0.39	0.86	0.37	8.66	8.94	7.99	8.66	4.72	10.80	9.92
	mm	120.0	120.0	10.0	21.8	9.5	220.0	227.0	203.0	220.0	120.0	4.9	4.50
3/4	Inch	5.51	5.51	0.51	1.07	0.59	9.84	10.31	9.76	9.84	6.30	15.65	14.33
	mm	140.0	140.0	13.0	27.2	15.0	250.0	262.0	248.0	250.0	160.0	7.1	6.50
1	Inch	5.51	5.51	0.51	1.33	0.79	10.51	10.98	10.12	10.51	6.30	19.62	17.64
	mm	140.0	140.0	13.0	33.9	20.0	267.0	279.0	257.0	267.0	160.0	8.9	8.00
1-1/4	Inch	6.50	7.09	0.51	1.68	1.02	12.20	12.80	12.05	12.20	8.66	33.07	34.17
	mm	165.0	180.0	13.0	42.7	26.0	310.0	325.0	306.0	310.0	220.0	15.0	15.50
1-1/2	Inch	8.66	8.86	0.51	1.92	1.12	13.58	14.37	12.48	13.58	8.66	48.50	48.50
	mm	220.0	225.0	13.0	48.8	28.5	345.0	365.0	317.0	345.0	220.0	22.0	22.00
2	Inch	8.66	8.86	0.65	2.41	1.44	13.58	14.37	12.48	13.58	8.66	48.50	48.50
	mm	220.0	225.0	16.5	61.2	36.5	345.0	365.0	317.0	345.0	220.0	22.0	22.00

Y-Pattern Piston Check Valve Standard Port

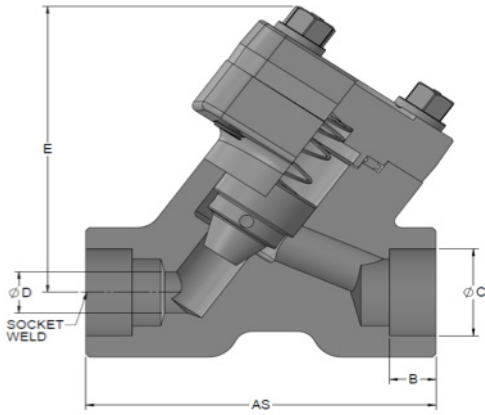

510 Series: Bolted Bonnet

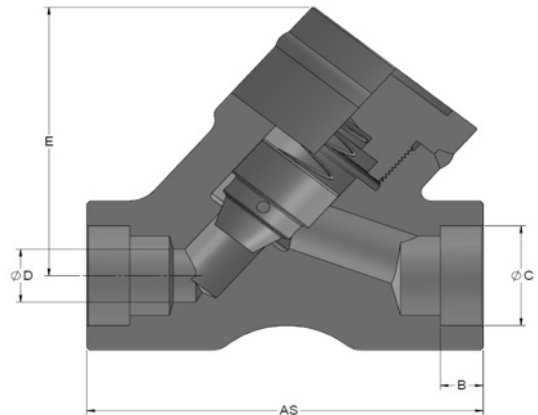

513 Series: Welded Bonnet

STANDARDS				
DESIGN:	API 602	PRESSURE CLASS:	NPT, SW & BW - 800, 1500	
	MSS SP-118		CONNECTIONS:	NPT - ASME B1.20.1
	ASME B16.34			SW - ASME B16.11
TESTING:	API 598		BW- ASME B16.25	

DIMENSIONS									WGT.(lb/kg)	
SIZE		AS [510]	AS [513]	B (Min)	C (Min)	D(Min)-SW	E-SW [510]	E-SW [513]	SW [510]	SW [513]
1/4	Inch	3.86	3.74	0.39	0.56	0.27	3.62	2.76	3.09	3.31
	mm	98	95	10	14.2	6.8	92.0	70.0	1.40	1.50
3/8	Inch	3.86	3.74	0.39	0.69	0.27	3.62	2.76	3.09	3.31
	mm	98	95	10	17.6	6.8	92.0	70.0	1.40	1.50
1/2	Inch	3.86	3.74	0.39	0.86	0.37	3.62	2.76	2.87	3.09
	mm	98.0	95.0	10.0	21.8	9.5	92.0	70.0	1.30	1.40
3/4	Inch	3.86	4.37	0.51	1.07	0.49	3.62	3.23	2.87	3.97
	mm	98.0	111.0	13.0	27.2	12.5	92.0	82.0	1.30	1.80
1	Inch	4.72	4.72	0.51	1.33	0.69	4.41	3.62	7.94	7.05
	mm	120.0	120.0	13.0	33.9	17.5	112.0	92.0	3.60	3.20
1-1/4	Inch	5.51	5.51	0.51	1.68	0.93	4.92	4.53	9.92	9.92
	mm	140.0	140.0	13.0	42.7	23.5	125.0	115.0	4.50	4.50
1-1/2	Inch	5.51	5.51	0.51	1.92	1.12	5.51	4.92	14.11	14.11
	mm	140.0	140.0	13.0	48.8	28.5	140.0	125.0	6.40	6.40
2	Inch	6.50	7.09	0.65	2.41	1.44	6.69	5.91	24.25	21.38
	mm	165.0	180.0	16.5	61.2	36.5	170.0	150.0	11.00	9.70

DIMENSIONS									WGT.(lb/kg)	
SIZE		AS [510]	AS [513]	B (Min)	C (Min)	D(Min)-SW	E-SW [510]	E-SW [513]	SW [510]	SW [513]
1/2	Inch	4.72	4.72	0.39	0.86	0.37	4.33	3.62	9.26	7.05
	mm	120.0	120.0	10.0	21.8	9.5	110.0	92.0	4.2	3.2
3/4	Inch	4.72	4.72	0.51	1.07	0.49	4.33	3.62	9.26	7.05
	mm	120.0	120.0	13.0	27.2	12.5	110.0	92.0	4.2	3.2
1	Inch	5.51	5.51	0.51	1.33	0.69	4.92	4.53	11.46	11.24
	mm	140.0	140.0	13.0	33.9	17.5	125.0	115.0	5.2	5.1
1-1/4	Inch	5.51	5.51	0.51	1.68	0.93	5.31	4.92	15.43	14.77
	mm	140.0	140.0	13.0	42.7	23.5	135.0	125.0	7.0	6.7
1-1/2	Inch	6.50	7.09	0.51	1.92	1.12	6.50	5.91	26.68	22.93
	mm	165.0	180.0	13.0	48.8	28.5	165.0	150.0	12.1	10.4
2	Inch	8.66	8.86	0.65	2.41	1.44	6.69	6.30	38.80	36.16
	mm	220.0	225.0	16.5	61.2	36.5	170.0	160.0	17.6	16.4

Y-Pattern Piston Check Valve Full Port

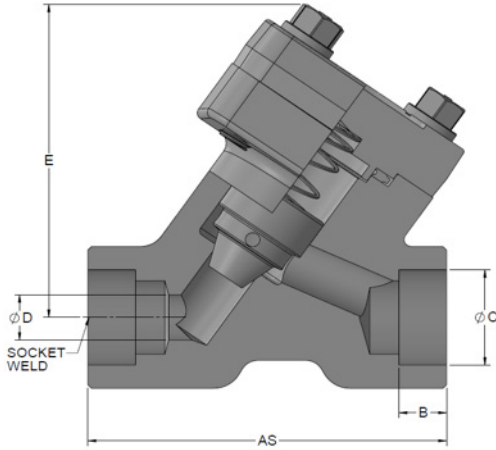

510 Series: Bolted Bonnet

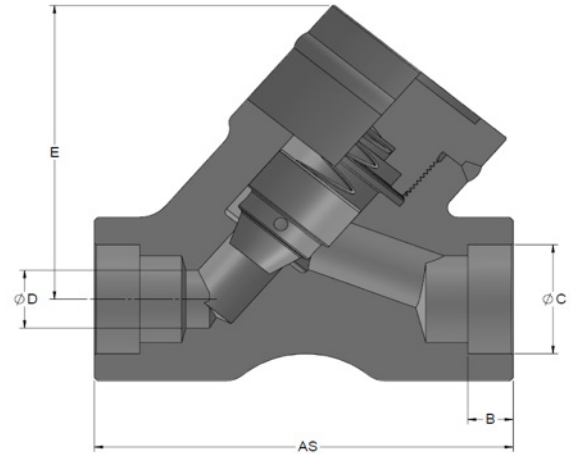

513 Series: Welded Bonnet

STANDARDS				
DESIGN:	API 602	PRESSURE CLASS:	NPT, SW & BW - 800, 1500	
	MSS SP-118		CONNECTIONS:	NPT - ASME B1.20.1
	ASME B16.34			SW - ASME B16.11
TESTING:	API 598		BW- ASME B16.25	

DIMENSIONS									WGT.(lb/kg)	
SIZE		AS [510]	AS [513]	B [Min]	C [Min]	D(Min)-SW	E-SW [510]	E-SW [513]	SW [510]	SW [513]
1/4	Inch	3.86	3.74	0.39	0.56	0.27	3.62	2.76	3.09	3.97
	mm	98.0	95.0	10.0	14.2	6.8	92.0	70.0	1.40	1.80
3/8	Inch	3.86	3.74	0.39	0.69	0.37	3.62	2.76	3.09	3.97
	mm	98.0	95.0	10.0	17.6	9.5	92.0	70.0	1.40	1.80
1/2	Inch	3.86	4.37	0.39	0.86	0.49	3.62	3.23	2.87	3.75
	mm	98.0	111.0	10.0	21.8	12.5	92.0	82.0	1.30	1.70
3/4	Inch	4.72	4.72	0.51	1.07	0.69	4.33	3.62	7.72	6.83
	mm	120.0	120.0	13.0	27.2	17.5	110.0	92.0	3.50	3.10
1	Inch	5.51	5.51	0.51	1.33	0.89	4.92	4.53	9.70	9.70
	mm	140.0	140.0	13.0	33.9	22.5	125.0	115.0	4.40	4.40
1-1/4	Inch	5.51	5.51	0.51	1.68	1.12	5.31	4.92	13.89	13.89
	mm	140.0	140.0	13.0	42.7	28.5	135.0	125.0	6.30	6.30
1-1/2	Inch	6.50	7.09	0.51	1.92	1.40	5.51	5.31	24.03	21.16
	mm	165.0	180.0	13.0	48.8	35.5	140.0	135.0	10.90	9.60
2	Inch	8.66	8.86	0.65	2.41	1.75	6.69	5.91	39.02	36.38
	mm	220.0	225.0	16.5	61.2	44.5	170.0	150.0	17.70	16.50

DIMENSIONS -1500									WGT.(lb/kg)	
SIZE		AS [510]	AS [513]	B [Min]	C [Min]	D(Min)-SW	E-SW [510]	E-SW [513]	SW [510]	SW [513]
1/2	Inch	4.72	4.72	0.39	0.86	0.37	3.62	3.23	8.60	7.50
	mm	120.0	120.0	10.0	21.8	9.5	92.0	82.0	3.90	3.40
3/4	Inch	5.51	5.51	0.51	1.07	0.59	4.41	3.62	9.92	10.14
	mm	140.0	140.0	13.0	27.2	15.0	112.0	92.0	4.50	4.60
1	Inch	5.51	5.51	0.51	1.33	0.79	4.92	4.53	14.33	14.33
	mm	140.0	140.0	13.0	33.9	20.0	125.0	115.0	6.50	6.50
1-1/4	Inch	6.50	7.09	0.51	1.68	1.02	5.51	5.31	26.46	24.25
	mm	165.0	180.0	13.0	42.7	26.0	140.0	135.0	12.00	11.00
1-1/2	Inch	8.66	8.86	0.51	1.92	1.12	6.69	5.91	39.68	37.48
	mm	220.0	225.0	13.0	48.8	28.5	170.0	150.0	18.00	17.00
2	Inch	8.66	8.86	0.65	2.41	1.44	6.69	5.91	39.24	36.60
	mm	220.0	225.0	16.5	61.2	36.5	170.0	150.0	17.80	16.60

Ball Check Valve Standard Port

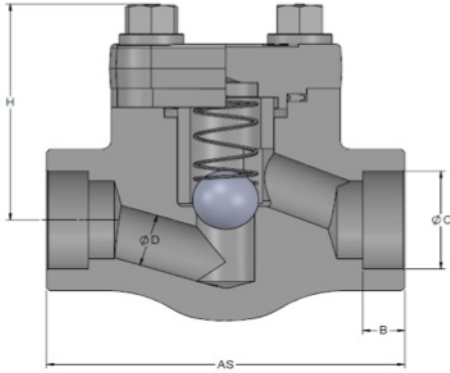

530 Series: Bolted Bonnet

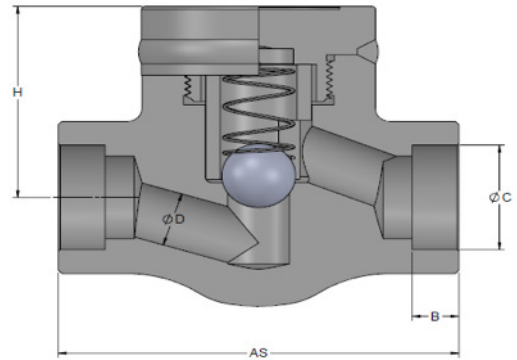
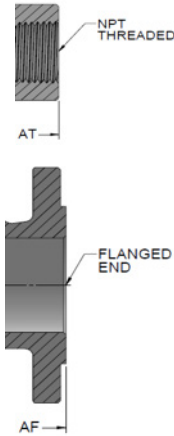

532 Series: Welded Bonnet

STANDARDS				
DESIGN:	API 602	TESTING:	API 598	
	MSS SP-118		CONNECTIONS:	NPT - ASME B1.20.1
	ASME B16.34			SW - ASME B16.11
	FACE TO FACE-ASME B16.10			BW- ASME B16.25
PRESSURE CLASS:	NPT, SW & BW - 800, 1500	FLANGED - ASME B16.5		
	FLANGED - 150, 300, 600, 1500			

STANDARD MATERIAL LIST							
Part Name	A105	LF2	F5	F9	F11	F22	F316/F316L
Ball	A276-440C						A182-F316
Guide	A276-410						A276-316
Spring	A276-316						

SIZE		DIMENSIONS										WGT.(lb/kg)								
		AT/AS 800	AF-150	AF-300	AF-600	B (Min)	C (Min)	D(Min)-NPT/SW	D(Min)-RF	H-530 (150)	H-530 (300)	H-530 (600)	H-530 (800)	H-532 (800)	150 (530)	300 (530)	600 (530)	800 (530)	800 (532)	
1/4	Inch	3.11	/	/	/	0.37	0.56	0.27	/	/	/	/	2.28	1.97	/	/	/	/	3.53	3.09
	mm	79.0	/	/	/	9.5	14.2	6.8	/	/	/	/	58.0	50.0	/	/	/	/	1.6	1.4
3/8	Inch	3.11	/	/	/	0.37	0.69	0.27	/	/	/	/	2.28	1.97	/	/	/	/	3.53	3.09
	mm	79.0	/	/	/	9.5	17.6	6.8	/	/	/	/	58.0	50.0	/	/	/	/	1.6	1.4
1/2	Inch	3.11	4.25	5.98	6.50	0.39	0.86	0.37	0.37	2.20	2.20	2.28	2.28	1.97	4.85	6.17	7.05	3.31	2.87	
	mm	79.0	108.0	152.0	165.0	10.0	21.8	9.5	9.5	56.0	56.0	58.0	58.0	50.0	2.2	2.8	3.2	1.5	1.3	
3/4	Inch	3.62	4.61	7.01	7.48	0.51	1.07	0.49	0.49	2.20	2.28	2.28	2.28	2.05	5.95	9.26	9.92	3.75	3.31	
	mm	92.0	117.0	178.0	190.0	13.0	27.2	12.5	12.5	56.0	58.0	58.0	58.0	52.0	2.7	4.2	4.5	1.7	1.5	
1	Inch	4.37	5.00	7.99	8.50	0.51	1.33	0.69	0.69	2.95	2.95	2.95	2.95	2.76	9.70	13.89	15.21	5.95	5.51	
	mm	111.0	127.0	203.0	216.0	13.0	33.9	17.5	17.5	75.0	75.0	75.0	75.0	70.0	4.4	6.3	6.9	2.7	2.5	
1-1/4	Inch	4.72	5.51	8.50	9.02	0.51	1.68	0.93	0.93	3.35	3.35	3.35	3.35	3.23	13.67	18.74	27.12	8.60	9.26	
	mm	120.0	140.0	216.0	229.0	13.0	42.7	23.5	23.5	85.0	85.0	85.0	85.0	82.0	6.2	8.5	12.3	3.9	4.2	
1-1/2	Inch	5.98	6.50	9.02	9.49	0.51	1.92	1.12	1.12	3.82	3.82	3.82	3.82	3.78	17.64	25.79	28.66	11.68	12.57	
	mm	152.0	165.0	229.0	241.0	13.0	48.8	28.5	28.5	97.0	97.0	97.0	97.0	96.0	8.0	11.7	13.0	5.3	5.7	
2	Inch	6.77	7.99	10.51	11.50	0.65	2.41	1.44	1.44	4.65	4.65	4.53	4.25	4.33	30.42	39.24	43.65	17.20	21.16	
	mm	172.0	203.0	267.0	292.0	16.5	61.2	36.5	36.5	118.0	118.0	115.0	108.0	110.0	13.8	17.8	19.8	7.8	9.6	

SIZE		DIMENSIONS-1500						WGT.(lb/kg)		
		AT/AS (530)	AT/AS (532)	B (Min)	C (Min)	D(Min)-NPT/SW	H (530)	H (532)	NPT/SW (530)	NPT/SW (532)
1/2	Inch	4.37	4.37	0.39	0.86	0.37	2.95	2.76	6.39	5.95
	mm	111.0	111.0	10.0	21.8	9.5	75.0	70.0	2.9	2.7
3/4	Inch	4.37	4.37	0.51	1.07	0.49	2.95	2.76	6.39	5.95
	mm	111.0	111.0	13.0	27.2	12.5	75.0	70.0	2.9	2.7
1	Inch	4.72	4.72	0.51	1.33	0.69	3.35	3.23	9.04	9.48
	mm	120.0	120.0	13.0	33.9	17.5	85.0	82.0	4.1	4.3
1-1/4	Inch	5.98	5.98	0.51	1.68	0.93	3.82	3.78	12.79	12.35
	mm	152.0	152.0	13.0	42.7	23.5	97.0	96.0	5.8	5.6
1-1/2	Inch	6.77	6.77	0.51	1.92	1.12	4.25	4.37	19.40	18.08
	mm	172.0	172.0	13.0	48.8	28.5	108.0	111.0	8.8	8.2
2	Inch	8.66	8.66	0.65	2.41	1.44	5.20	4.53	36.38	29.76
	mm	220.0	220.0	16.5	61.2	36.5	132.0	115.0	16.5	13.5

Ball Check Valve Full Port

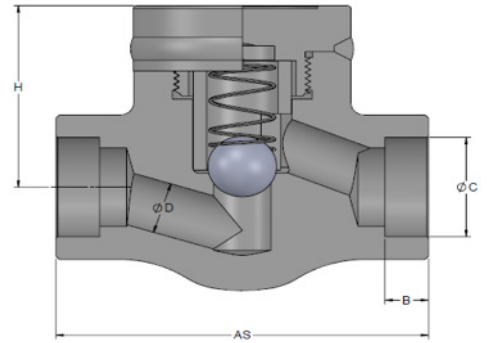
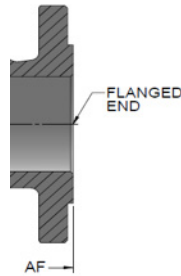
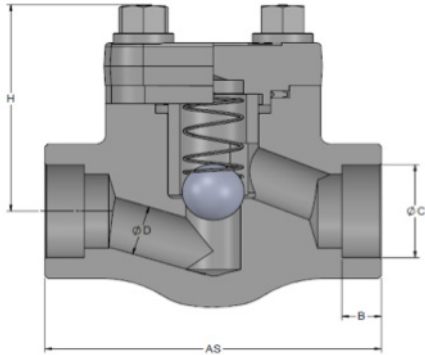

531 Series: Bolted Bonnet

533 Series: Welded Bonnet

STANDARDS				
DESIGN:	API 602	TESTING:	API 598	
	MSS SP-118		CONNECTIONS:	NPT - ASME B1.20.1
	ASME B16.34			SW - ASME B16.11
	FACE TO FACE-ASME B16.10			BW- ASME B16.25
PRESSURE CLASS:	NPT, SW & BW - 800	FLANGED - ASME B16.5		
	FLANGED - 150, 300, 600			

STANDARD MATERIAL LIST							
Part Name	A105	LF2	F5	F9	F11	F22	F316/F316L
Ball	A276-440C						A182-F316
Guide	A276-410						A276-316
Spring	A276-316						

SIZE		DIMENSIONS										WGT.(lb/Kg)				
		AS 800	AF-150	AF-300	AF-600	B (Min)	C (Min)	D(Min)SW	D(Min)RF	H (531)	H (533)	150 (531)	300 (531)	600 (531)	800 (531)	800 (533)
1/4	Inch	3.62	/	/	/	0.37	0.56	0.27	/	2.28	2.05	/	/	/	4.19	4.19
	mm	92.0	/	/	/	9.5	14.2	6.8	/	58.0	52.0	/	/	/	1.9	1.9
3/8	Inch	3.62	/	/	/	0.37	0.69	0.37	/	2.28	2.05	/	/	/	3.97	3.97
	mm	92.0	/	/	/	9.5	17.6	9.5	/	58.0	52.0	/	/	/	1.8	1.8
1/2	Inch	3.62	4.25	5.98	6.50	0.37	0.86	0.49	0.49	2.28	2.05	10.14	10.58	12.79	3.75	3.75
	mm	92.0	108.0	152.0	165.0	9.5	21.8	12.5	12.5	58.0	52.0	4.6	4.8	5.8	1.7	1.7
3/4	Inch	4.37	4.61	7.01	7.48	0.49	1.07	0.69	0.69	2.95	2.76	18.74	19.40	20.94	8.38	6.83
	mm	111.0	117.0	178.0	190.0	12.5	27.2	17.5	17.5	75.0	70.0	8.5	8.8	9.5	3.8	3.1
1	Inch	4.72	5.00	7.99	8.50	0.49	1.33	0.89	0.89	3.35	3.23	20.28	21.16	22.93	13.01	11.46
	mm	120.0	127.0	203.0	216.0	12.5	33.9	22.5	22.5	85.0	82.0	9.2	9.6	10.4	5.9	5.2
1-1/4	Inch	5.98	5.51	8.50	9.02	0.49	1.68	1.12	1.12	3.82	3.74	27.56	30.20	34.39	16.75	15.43
	mm	152.0	140.0	216.0	229.0	12.5	42.7	28.5	28.5	97.0	95.0	12.5	13.7	15.6	7.6	7.0
1-1/2	Inch	6.77	6.50	9.02	9.49	0.49	1.92	1.40	1.40	4.25	4.33	32.63	39.24	54.01	22.71	23.15
	mm	172.0	165.0	229.0	241.0	12.5	48.8	35.5	35.5	108.0	110.0	14.8	17.8	24.5	10.3	10.5
2	Inch	8.66	7.99	10.51	11.50	0.63	2.41	1.75	1.75	5.71	4.53	37.04	43.65	58.42	38.14	34.83
	mm	220.0	203.0	267.0	292.0	16.0	61.2	44.5	44.5	145.0	115.0	16.8	19.8	26.5	17.3	15.8

SIZE		DIMENSIONS-1500							WGT.(lb/Kg)	
		AS (531)	AS (533)	B (Min)	C (Min)	D (Min)	H (531)	H (533)	SW (531)	SW (533)
1/2	Inch	4.37	4.37	0.39	0.86	0.37	2.95	2.76	6.39	7.05
	mm	111.0	111.0	10.0	21.8	9.5	75.0	70.0	2.9	3.2
3/4	Inch	4.72	4.72	0.51	1.07	0.59	3.35	3.23	9.26	11.68
	mm	120.0	120.0	13.0	27.2	15.0	85.0	82.0	4.2	5.3
1	Inch	5.98	5.98	0.51	1.33	0.79	3.82	3.74	13.01	15.87
	mm	152.0	152.0	13.0	33.9	20.0	97.0	95.0	5.9	7.2
1-1/4	Inch	6.77	6.77	0.51	1.68	1.02	4.25	4.33	19.62	23.59
	mm	172.0	172.0	13.0	42.7	26.0	108.0	110.0	8.9	10.7
1-1/2	Inch	6.77	6.77	0.51	1.92	1.12	4.25	4.33	19.40	23.59
	mm	172.0	172.0	13.0	48.8	28.5	108.0	110.0	8.8	10.7
2	Inch	8.66	8.66	0.65	2.41	1.44	5.20	4.53	36.38	34.83
	mm	220.0	220.0	16.5	61.2	36.5	132.0	115.0	16.5	15.8

Extended Body Gate Valve Standard Port

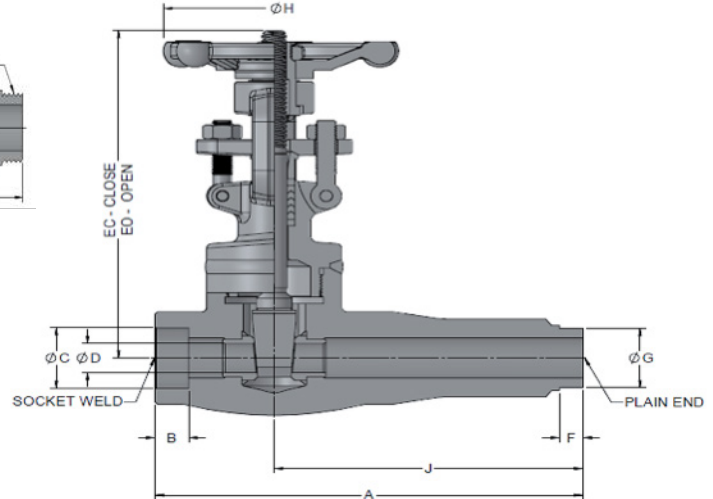
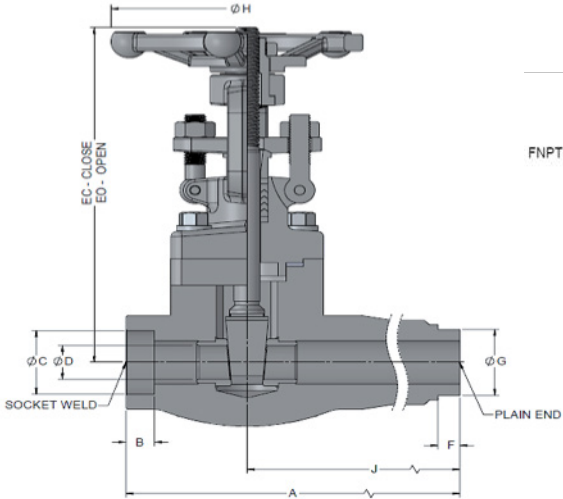

501 Series: Bolted Bonnet

505 Series: Welded Bonnet

STANDARDS			
DESIGN:	API 602	CONNECTIONS:	NPT - ASME B1.20.1
	ASME B16.34		SW - ASME B16.11
TESTING:	API 598		BW - ASME B16.25
PRESSURE CLASS:	NPT, SW & BW - 800		PE - API 602

SIZE		DIMENSIONS											WGT.(lb/Kg)		
		A	B (Min)	C (Min)	D (Min)	EC (501)	EO (501)	EC (505)	EO (505)	F	J	G	H	501	505
1/2	Inch	5.89	0.39	0.86	0.37	5.59	6.18	5.63	6.22	0.31	4.33	0.84	3.94	5.07	4.41
	mm	149.5	10.0	21.8	9.5	142.0	157.0	143.0	158.0	7.9	110.0	21.3	100.0	2.3	2.0
3/4	Inch	6.14	0.51	1.07	0.51	5.59	6.18	5.79	6.38	0.44	4.33	1.05	3.94	5.51	5.07
	mm	156.0	13.0	27.2	13.0	142.0	157.0	147.0	162.0	11.2	110.0	26.7	100.0	2.5	2.3
1	Inch	6.91	0.51	1.33	0.71	6.50	7.28	7.01	7.80	0.44	4.72	1.31	4.72	8.60	9.26
	mm	175.5	13.0	33.9	18.0	165.0	185.0	178.0	198.0	11.2	120.0	33.4	120.0	3.9	4.2
1-1/2	Inch	7.87	0.51	1.92	1.14	8.23	9.49	8.31	9.61	0.44	5.51	1.90	6.30	15.87	15.87
	mm	200.0	13.0	48.8	29.0	209.0	241.0	211.0	244.0	11.2	140.0	48.3	160.0	7.2	7.2
2	Inch	8.66	0.65	2.41	1.44	9.02	10.75	9.45	11.18	0.56	5.91	2.37	8.66	23.15	24.69
	mm	220.0	16.5	61.2	36.5	229.0	273.0	240.0	284.0	14.2	150.0	60.3	220.0	10.5	11.2

Reinforced Extended Body Gate Valve Standard Port

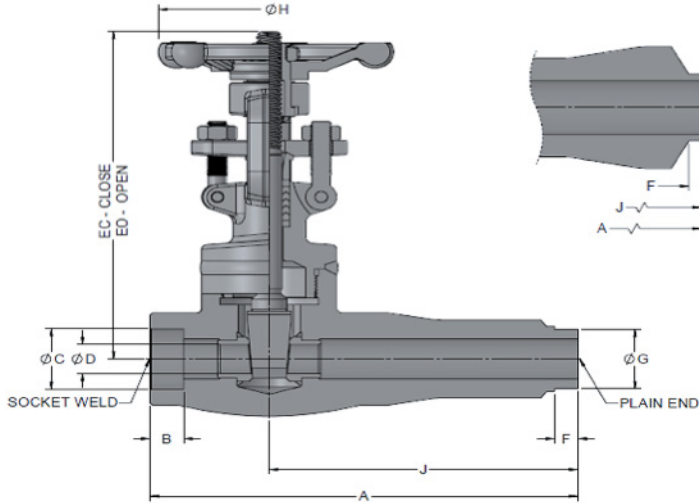

501 Series: Bolted Bonnet

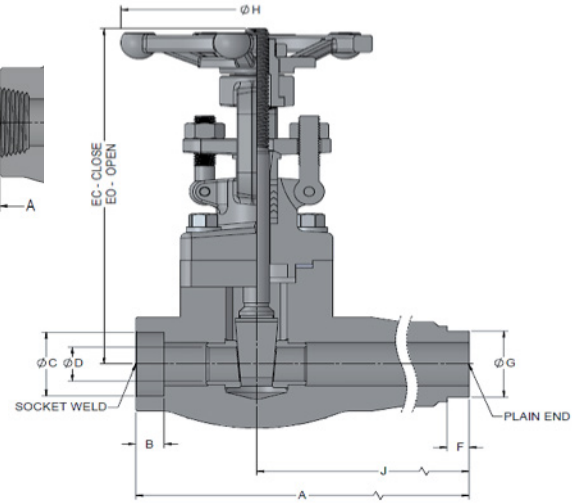

505 Series: Welded Bonnet

STANDARDS			
DESIGN:	API 602	CONNECTIONS:	NPT - ASME B1.20.1
	ASME B16.34		SW - ASME B16.11
TESTING:	API 598		LIP END/BW - ASME B16.25
PRESSURE CLASS:	NPT, SW & BW - 800		PE - API 602

DIMENSIONS															WGT.(lb/Kg)		
SIZE		A	B (Min)	C (Min)	D (Min)	EC (501)	EO (501)	EC (505)	EO (505)	F	J	G	K	M	H	501	505
1/2	Inch	8.15	0.39	0.86	0.37	5.59	6.18	5.63	6.22	0.16	6.59	0.87	1.38	0.69	3.94	5.73	5.07
	mm	207.0	10.0	21.8	9.5	142.0	157.0	143.0	158.0	4.0	167.5	22.0	35.0	17.5	100.0	2.6	2.3
3/4	Inch	8.60	0.51	1.07	0.51	5.59	6.18	5.79	6.38	0.19	6.79	1.18	1.57	0.87	3.94	6.17	5.73
	mm	218.5	13.0	27.2	13.0	142.0	157.0	147.0	162.0	4.8	172.5	30.0	40.0	22.0	100.0	2.8	2.6
1	Inch	9.63	0.51	1.33	0.71	6.50	7.28	7.01	7.80	0.19	7.44	1.44	1.97	1.12	4.72	9.48	10.14
	mm	244.5	13.0	33.9	18.0	165.0	185.0	178.0	198.0	4.8	189.0	36.5	50.0	28.5	120.0	4.3	4.6
1-1/2	Inch	10.37	0.51	1.92	1.14	8.23	9.49	8.31	9.61	0.25	8.01	1.99	2.68	1.61	6.30	17.64	17.64
	mm	263.5	13.0	48.8	29.0	209.0	241.0	211.0	244.0	6.3	203.5	50.5	68.0	41.0	160.0	8.0	8.0
2	Inch	10.53	0.65	2.41	1.44	9.02	10.75	9.45	11.18	0.31	7.78	2.56	3.15	1.81	8.66	25.79	27.34
	mm	267.5	16.5	61.2	36.5	229.0	273.0	240.0	284.0	8.0	197.5	65.0	80.0	46.0	220.0	11.7	12.4

501 Cryogenic/Extended Bonnet Gate Valve, Standard Port

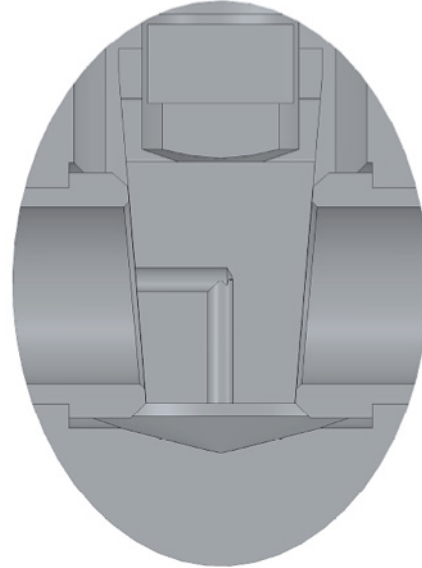
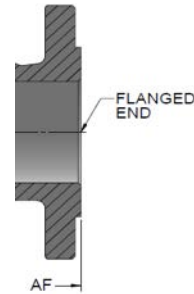
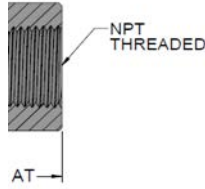
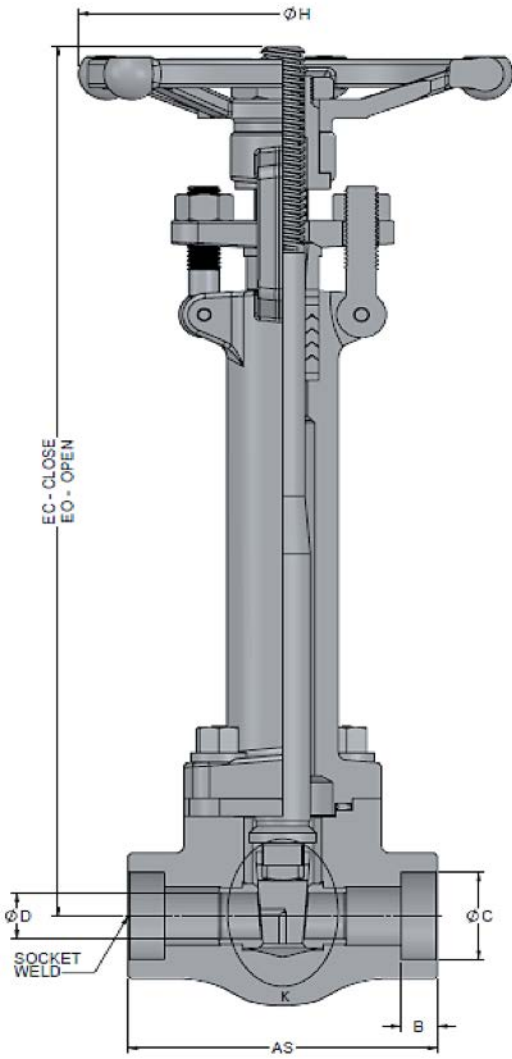

DETAIL K
CRYOGENIC WEDGE DESIGN

STANDARDS	
DESIGN:	API 602 ASME B16.34 MSS SP-134 (when specified) FACE TO FACE - ASME B16.10
TESTING:	API 598
PRESSURE CLASS:	NPT, SW & BW - 800 FLANGED - 150, 300, 600
CONNECTIONS:	NPT - ASME B1.20.1 SW - ASME B16.11 BW - ASME B16.25 FLANGED - ASME B16.5

DIMENSIONS															WGTL.(lb/kg)				
SIZE		AT/AS 800	AF- 150	AF-300	AF-600	B (Min)	C (Min)	D(Min)- NPT/SW	D(Min)-RF	EC-NPT/ SW	EO-NPT/ SW	EC-RF	EO-RF	H	RF 150	RF 300	RF 600	NPT/SW 800	
1/4	Inch	3.11	/	/	/	0.39	0.56	0.30	/	16.06	16.65	/	/	4.72	/	/	/	/	10.36
	mm	79.0	/	/	/	10.0	14.2	7.5	/	408.0	423.0	/	/	120.0	/	/	/	/	4.7
3/8	Inch	3.11	/	/	/	0.39	0.69	0.39	/	16.06	16.65	/	/	4.72	/	/	/	/	10.14
	mm	79.0	/	/	/	10.0	17.6	10	/	408.0	423.0	/	/	120.0	/	/	/	/	4.6
1/2	Inch	3.11	4.25	5.51	6.50	0.39	0.86	0.51	0.37	16.06	16.65	16.06	16.65	4.72	11.68	13.01	13.89	9.92	
	mm	79.0	108.0	140.0	165.0	10.0	21.8	13.0	9.5	408.0	423.0	408.0	423.0	120.0	5.3	5.9	6.3	4.5	
3/4	Inch	3.62	4.61	5.98	7.48	0.51	1.07	0.51	0.51	16.06	16.65	16.06	16.65	4.72	13.01	15.43	16.53	10.58	
	mm	92.0	117.0	152.0	190.0	13.0	27.2	13.0	13.0	408.0	423.0	408.0	423.0	120.0	5.9	7.0	7.5	4.8	
1	Inch	4.37	5.00	6.50	8.50	0.51	1.33	0.71	0.71	17.32	18.11	17.32	18.11	6.30	19.40	22.49	24.25	16.31	
	mm	111.0	127.0	165.0	216.0	13.0	33.9	18.0	18.0	440.0	460.0	440.0	460.0	160.0	8.8	10.2	11.0	7.4	
1-1/2	Inch	4.72	6.50	7.48	9.49	0.51	1.92	1.14	1.14	18.43	19.61	18.43	19.61	8.66	28.88	34.61	39.90	23.37	
	mm	120.0	165.0	190.0	241.0	13.0	48.8	29.0	29.0	468.0	498.0	468.0	498.0	220.0	13.1	15.7	18.1	10.6	
2	Inch	5.51	7.01	8.50	11.50	0.65	2.41	1.44	1.44	19.69	21.22	19.69	21.22	8.66	41.23	47.84	56.00	33.73	
	mm	140.0	178.0	216.0	292.0	16.5	61.2	36.5	36.5	500.0	539.0	500.0	539.0	220.0	18.7	21.7	25.4	15.3	

502 Cryogenic/Extended Bonnet Globe Valve, Standard Port

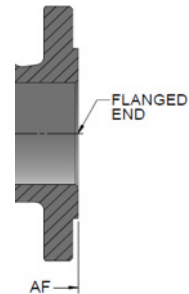
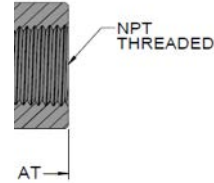
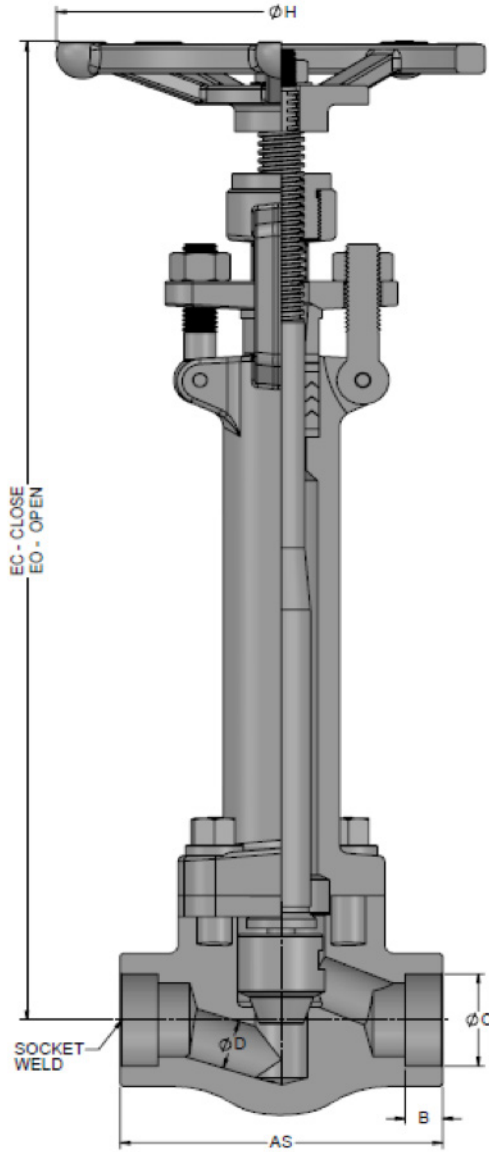

STANDARDS	
DESIGN:	API 602
	ASME B16.34
	MSS SP-134 (when specified)
	FACE TO FACE - ASME B16.10
TESTING:	API 598
PRESSURE CLASS:	NPT, SW & BW - 800
	FLANGED - 150, 300, 600
CONNECTIONS:	NPT - ASME B1.20.1
	SW - ASME B16.11
	BW - ASME B16.25
	FLANGED - ASME B16.5

DIMENSIONS															WGT.(lb/kg)			
SIZE		AT/AS 800	AF-150	AF-300	AF-600	B (Min)	C (Min)	D(Min)-NPT/SW	D(Min)-RF	EC-NPT/SW	EO-NPT/SW	EC-RF	EO-RF	H	RF 150	RF 300	RF 600	NPT/SW 800
1/4	Inch	3.11	/	/	/	0.39	0.56	0.27	/	16.73	17.20	/	/	4.72	/	/	/	10.36
	mm	79.0	/	/	/	10.0	14.2	6.8	/	425.0	437.0	/	/	120.0	/	/	/	4.7
3/8	Inch	3.11	/	/	/	0.39	0.69	0.27	/	16.73	17.20	/	/	4.72	/	/	/	10.36
	mm	79.0	/	/	/	10.0	17.6	6.8	/	425.0	437.0	/	/	120.0	/	/	/	4.7
1/2	Inch	3.11	4.25	5.98	6.50	0.39	0.86	0.37	0.37	16.73	17.01	16.73	17.01	4.72	12.13	13.45	14.33	10.14
	mm	79.0	108.0	152.0	165.0	10.0	21.8	9.5	9.5	425.0	432.0	425.0	432.0	120.0	5.5	6.1	6.5	4.6
3/4	Inch	3.62	4.61	7.01	7.48	0.51	1.07	0.49	0.49	16.73	17.01	16.73	17.01	4.72	13.01	16.09	16.75	10.58
	mm	92.0	117.0	178.0	190.0	13.0	27.2	12.5	12.5	425.0	432.0	425.0	432.0	120.0	5.9	7.3	7.6	4.8
1	Inch	4.37	5.00	7.99	8.50	0.51	1.33	0.69	0.69	17.91	18.54	17.91	18.54	6.30	20.50	24.91	26.01	17.42
	mm	111.0	127.0	203.0	216.0	13.0	33.9	17.5	17.5	455.0	471.0	455.0	471.0	160.0	9.3	11.3	11.8	7.9
1-1/2	Inch	5.98	6.50	9.02	9.49	0.51	1.92	1.12	1.12	19.06	19.92	19.06	19.92	8.66	31.31	39.68	42.11	26.68
	mm	152.0	165.0	229.0	241.0	13.0	48.8	28.5	28.5	484.0	506.0	484.0	506.0	220.0	14.2	18.0	19.1	12.1
2	Inch	6.77	7.99	10.51	11.50	0.65	2.41	1.44	1.44	20.67	21.81	20.67	21.81	8.66	45.19	53.13	57.32	36.16
	mm	172.0	203.0	267.0	292.0	16.5	61.2	36.5	36.5	525.0	554.0	525.0	554.0	220.0	20.5	24.1	26.0	16.4

Bellows Seal Gate Valve Standard Port

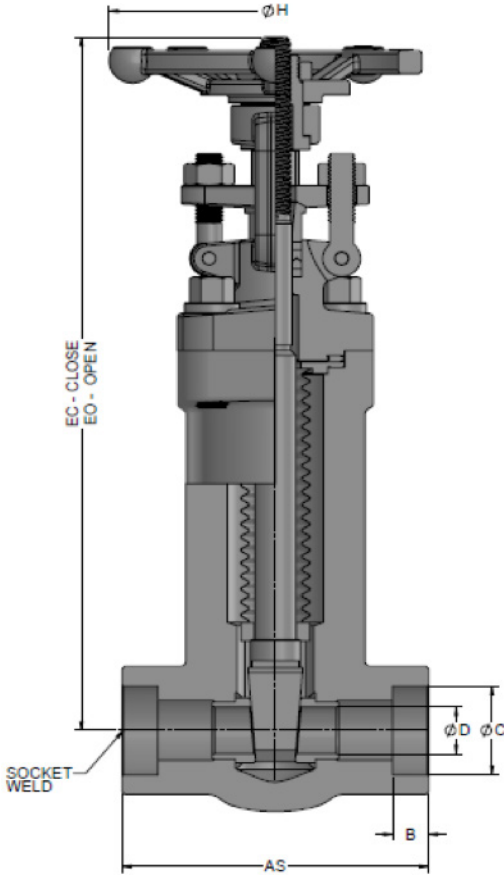

501 Series: Bolted Bonnet

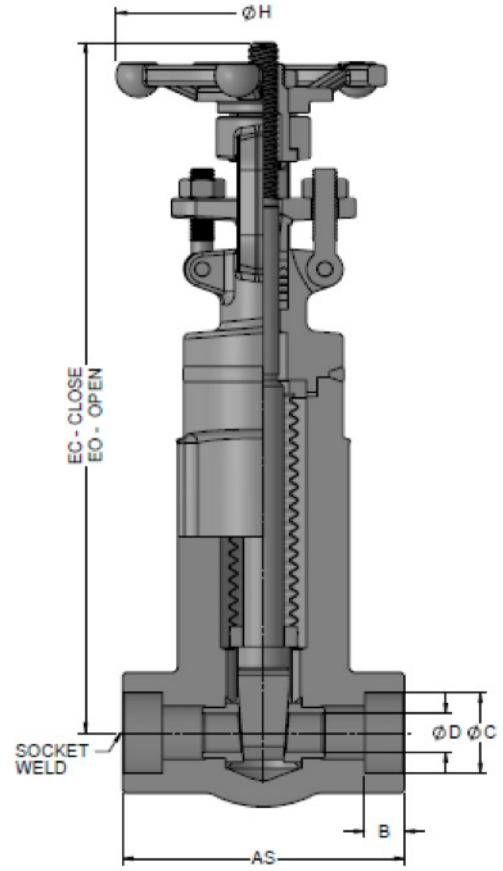

505 Series: Welded Bonnet

STANDARDS	
DESIGN:	API 602 ASME B16.34
TESTING:	API 598
PRESSURE CLASS:	NPT, SW & BW - 800
CONNECTIONS:	NPT - ASME B1.20.1 SW - ASME B16.11 BW - ASME B16.25

STANDARD MATERIAL LIST	
Part Name	SPECIFICATION
Bellows	F316L / F321

DIMENSIONS											WGT.(lb/kg)	
SIZE		AT/AS 800	B (Min)	C (Min)	D(Min)-NPT/ SW	EC-NPT/SW (501)	EO-NPT/SW (501)	EC-NPT/SW (505)	EO-NPT/SW (505)	H	NPT/SW (501)	NPT/SW (505)
1/4	Inch	3.11	0.39	0.56	0.30	8.90	9.49	9.17	9.76	3.94	7.28	7.05
	mm	79.0	10.0	14.2	7.5	226.0	241.0	233.0	248.0	100.0	3.3	3.2
3/8	Inch	3.11	0.39	0.69	0.39	8.90	9.49	9.17	9.76	3.94	7.05	6.83
	mm	79.0	10.0	17.6	10	226.0	241.0	233.0	248.0	100.0	3.2	3.1
1/2	Inch	3.11	0.39	0.86	0.51	8.90	9.49	9.17	9.76	3.94	6.83	6.61
	mm	79.0	10.0	21.8	13.0	226.0	241.0	233.0	248.0	100.0	3.1	3.0
3/4	Inch	3.62	0.51	1.07	0.51	8.90	9.49	9.17	9.76	3.94	7.28	7.05
	mm	92.0	13.0	27.2	13.0	226.0	241.0	233.0	248.0	100.0	3.3	3.2
1	Inch	4.37	0.51	1.33	0.71	10.39	11.22	10.71	11.50	4.72	11.90	11.68
	mm	111.0	13.0	33.9	18.0	264.0	285.0	272.0	292.0	120.0	5.4	5.3
1-1/2	Inch	4.72	0.51	1.92	1.14	13.94	15.12	13.94	15.16	6.30	22.49	22.05
	mm	120.0	13.0	48.8	29.0	354.0	384.0	354.0	385.0	160.0	10.2	10.0
2	Inch	5.51	0.65	2.41	1.44	16.14	17.72	16.14	17.72	8.66	32.63	32.19
	mm	140.0	16.5	61.2	36.5	410.0	450.0	410.0	450.0	220.0	14.8	14.6

Bellows Seal Gate Valve Full Port

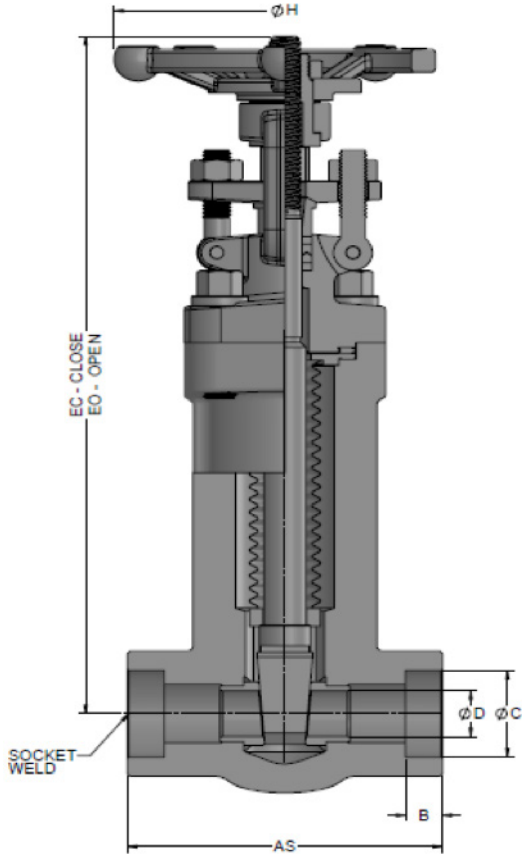

511 Series: Bolted Bonnet

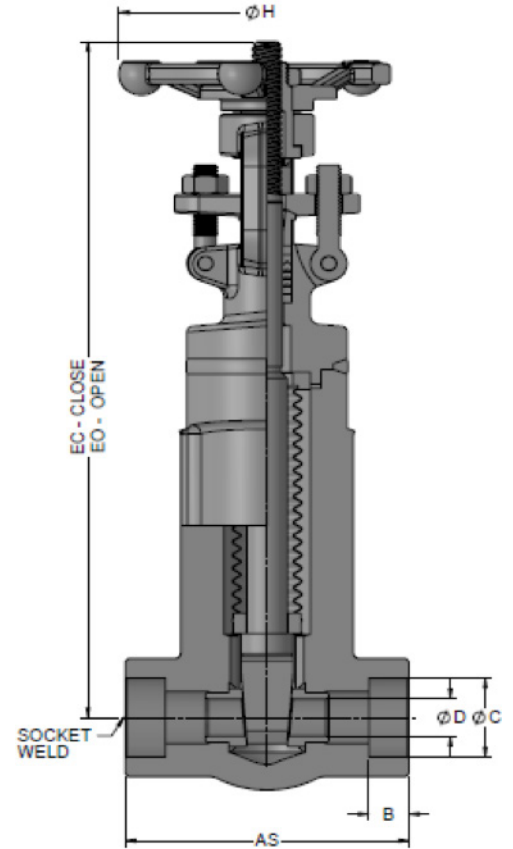
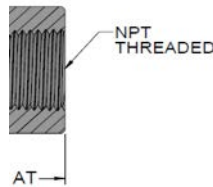

515 Series: Welded Bonnet

STANDARDS	
DESIGN:	API 602 ASME B16.34
TESTING:	API 598
PRESSURE CLASS:	NPT, SW & BW - 800
CONNECTIONS:	NPT - ASME B1.20.1 SW - ASME B16.11 BW - ASME B16.25

STANDARD MATERIAL LIST	
Part Name	SPECIFICATION
Bellows	F316L / F321

SIZE		DIMENSIONS									WGT.(lb/kg)	
		AT/AS 800	B (Min)	C (Min)	D (Min)-NPT/ SW	EC-NPT/SW (501)	EO-NPT/SW (501)	EC-NPT/SW (505)	EO-NPT/SW (505)	H	NPT/SW (501)	NPT/SW (505)
1/4	Inch	3.11	0.39	0.56	0.30	8.90	9.49	9.17	9.76	3.94	7.05	6.83
	mm	79.0	10.0	14.2	7.5	226	241	233	248	100.0	3.2	3.1
3/8	Inch	3.11	0.39	0.69	0.39	8.90	9.49	9.17	9.76	3.94	7.05	6.83
	mm	79.0	10.0	17.6	10	226	241	233	248	100.0	3.2	3.1
1/2	Inch	3.11	0.39	0.86	0.51	8.90	9.49	9.17	9.76	3.94	6.83	6.61
	mm	79.0	10.0	21.8	13.0	226.0	241.0	233.0	248.0	100.0	3.1	3.0
3/4	Inch	4.37	0.51	1.07	0.71	10.39	11.22	10.71	11.50	4.72	11.68	11.46
	mm	111.0	13.0	27.2	18.0	264.0	285.0	272.0	292.0	120.0	5.3	5.2
1	Inch	4.72	0.51	1.33	0.94	13.94	15.16	13.94	15.16	6.30	22.27	21.83
	mm	120.0	13.0	33.9	24.0	354.0	385.0	354.0	385.0	160.0	10.1	9.9
1-1/2	Inch	5.51	0.51	1.92	1.44	16.14	17.72	16.14	17.72	8.66	32.41	31.97
	mm	140.0	13.0	48.8	36.5	410.0	450.0	410.0	450.0	220.0	14.7	14.5

Bellows Seal Globe Valve Standard Port

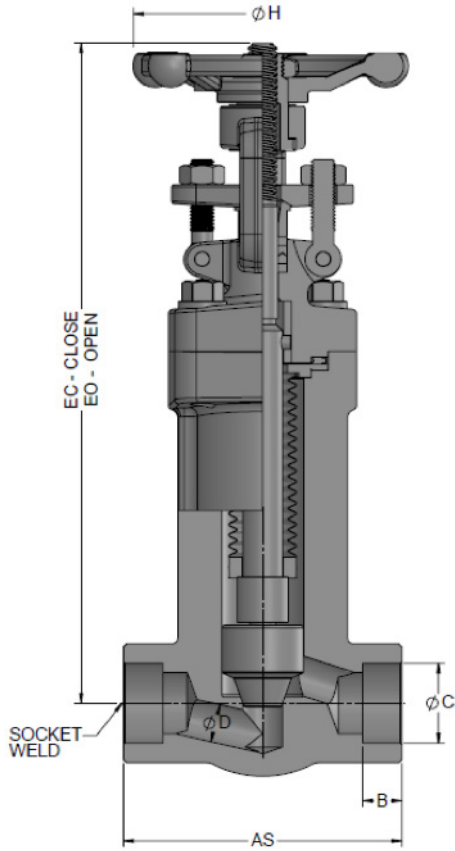

502 Series: Bolted Bonnet

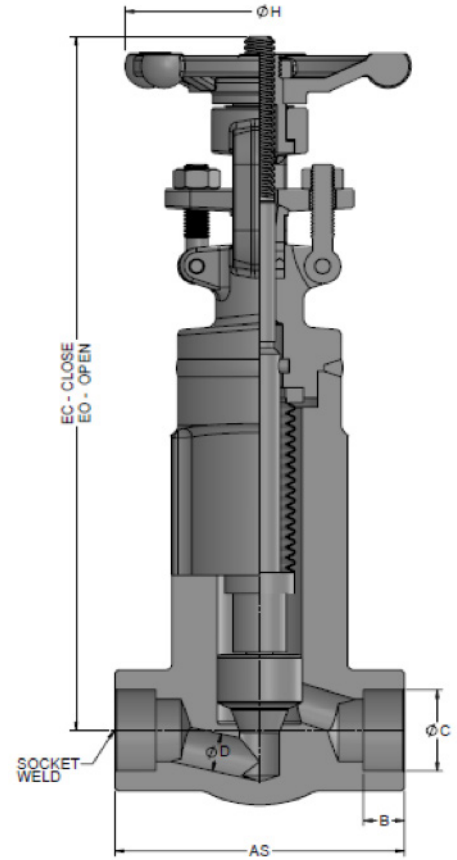

506 Series: Welded Bonnet

STANDARDS	
DESIGN:	API 602
	MSS SP-118
	ASME B16.34
TESTING:	API 598
PRESSURE CLASS:	NPT, SW & BW - 800
CONNECTIONS:	NPT - ASME B1.20.1
	SW - ASME B16.11
	BW - ASME B16.25

STANDARD MATERIAL LIST	
Part Name	SPECIFICATION
Bellows	F316L / F321

SIZE		DIMENSIONS									WGT.(lb./kg)	
		AT/AS 800	B (Min)	C (Min)	D (Min)-NPT/ SW	EC-NPT/SW (502)	EO-NPT/SW (502)	EC-NPT/SW (506)	EO-NPT/SW (506)	H	NPT/SW (502)	NPT/SW (506)
1/4	Inch	3.11	0.39	0.56	0.27	8.94	9.37	9.17	9.57	3.94	7.94	7.72
	mm	79.0	10.0	14.2	6.8	227.0	238.0	233.0	243.0	100.0	3.6	3.5
3/8	Inch	3.11	0.39	0.69	0.27	8.94	9.37	9.17	9.57	3.94	7.94	7.72
	mm	79.0	10.0	17.6	6.8	227.0	238.0	233.0	243.0	100.0	3.6	3.5
1/2	Inch	3.11	0.39	0.86	0.37	8.94	9.37	9.17	9.57	3.94	7.72	7.50
	mm	79.0	10.0	21.8	9.5	227.0	238.0	233.0	243.0	100.0	3.5	3.4
3/4	Inch	3.62	0.51	1.07	0.49	8.94	9.37	9.17	9.57	3.94	8.38	8.16
	mm	92.0	13.0	27.2	12.5	227.0	238.0	233.0	243.0	100.0	3.8	3.7
1	Inch	4.37	0.51	1.33	0.69	10.43	10.94	9.17	9.57	4.72	12.79	12.57
	mm	111.0	13.0	33.9	17.5	265.0	278.0	233.0	243.0	120.0	5.8	5.7
1-1/2	Inch	5.98	0.51	1.92	1.12	11.06	11.81	13.94	14.65	6.30	22.49	22.05
	mm	152.0	13.0	48.8	28.5	281.0	300.0	354.0	372.0	160.0	10.2	10.0
2	Inch	6.77	0.65	2.41	1.44	13.19	14.02	16.14	17.13	8.66	35.27	34.83
	mm	172.0	16.5	61.2	36.5	335.0	356.0	410.0	435.0	220.0	16.0	15.8

Bellows Seal Globe Valve Full Port

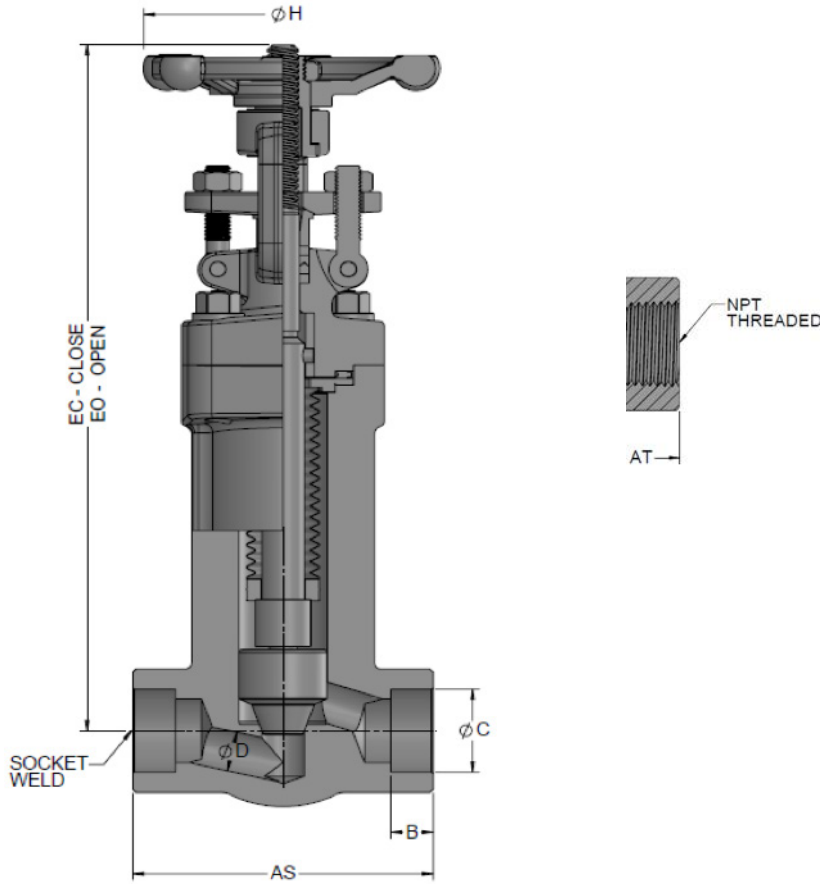

522 Series: Bolted Bonnet

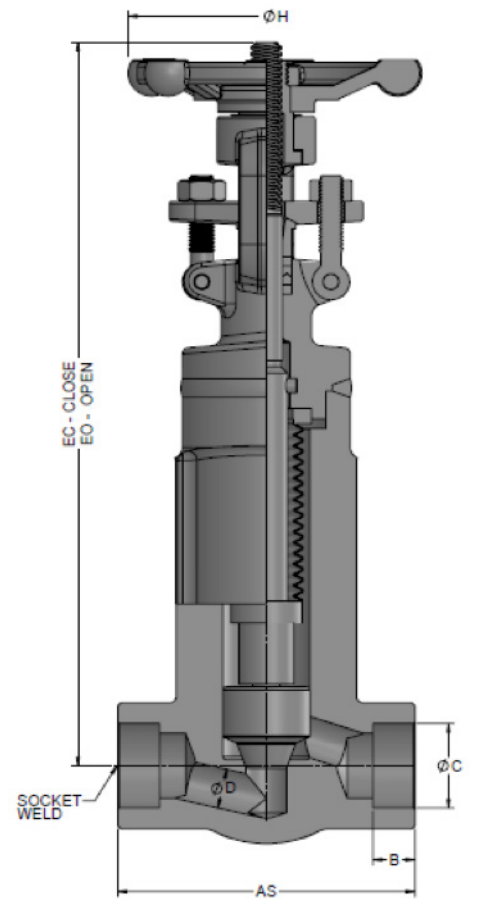

516 Series: Welded Bonnet

STANDARDS	
DESIGN:	API 602 MSS SP-118 ASME B16.34
TESTING:	API 598
PRESSURE CLASS:	NPT, SW & BW - 800
CONNECTIONS:	NPT - ASME B1.20.1 SW - ASME B16.11 BW - ASME B16.25

STANDARD MATERIAL LIST	
Part Name	SPECIFICATION
Bellows	F316L / F321

SIZE		DIMENSIONS								WGT.(lb./kg)		
		AT/AS 800	B (Min)	C (Min)	D (Min)-NPT/SW	EC-NPT/ SW (502)	EO-NPT/SW (502)	EC-NPT/SW (506)	EO-NPT/SW (506)	H	NPT/SW (502)	NPT/SW (506)
1/4	Inch	3.11	0.39	0.56	0.27	8.94	9.37	9.17	9.57	3.94	7.94	7.72
	mm	79.0	10.0	14.2	6.8	227.0	238.0	233.0	243.0	100.0	3.6	3.5
3/8	Inch	3.11	0.39	0.69	0.37	8.94	9.37	9.17	9.57	3.94	7.72	7.50
	mm	79.0	10.0	17.6	9.5	227.0	238.0	233.0	243.0	100.0	3.5	3.4
1/2	Inch	3.62	0.39	0.86	0.49	8.94	9.37	9.17	9.57	3.94	8.38	8.16
	mm	92.0	10.0	21.8	12.5	227.0	238.0	233.0	243.0	100.0	3.8	3.7
3/4	Inch	4.37	0.51	1.07	0.69	10.43	10.94	9.17	9.57	4.72	12.57	12.35
	mm	111.0	13.0	27.2	17.5	265.0	278.0	233.0	243.0	120.0	5.7	5.6
1	Inch	5.98	0.51	1.33	0.89	11.06	11.81	13.94	14.65	6.30	22.27	21.83
	mm	152.0	13.0	33.9	22.5	281.0	300.0	354.0	372.0	160.0	10.1	9.9
1-1/2	Inch	6.77	0.51	1.92	1.40	13.19	14.02	16.14	17.13	8.66	35.05	34.61
	mm	172.0	13.0	48.8	35.5	335.0	356.0	410.0	435.0	220.0	15.9	15.7



Global Headquarters: 6059 South Loop East • Houston, TX 77087 • www.BericValves.com
Toll Free: 866-GO Beric (462-3742) • Phone: 713-673-2073 • Fax: 713-673-4641 • Sales@BericValves.com