

3700

SERIES

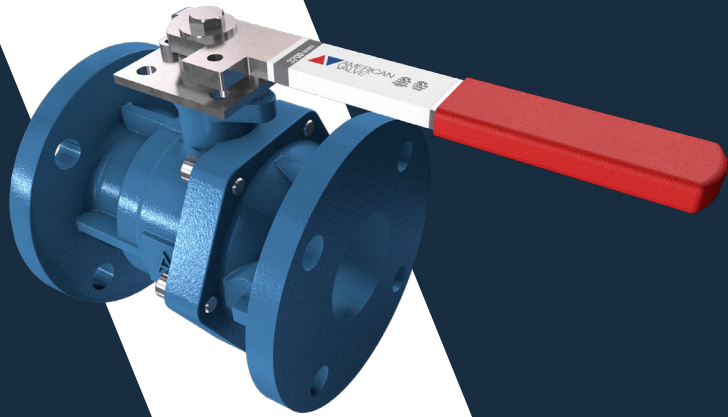

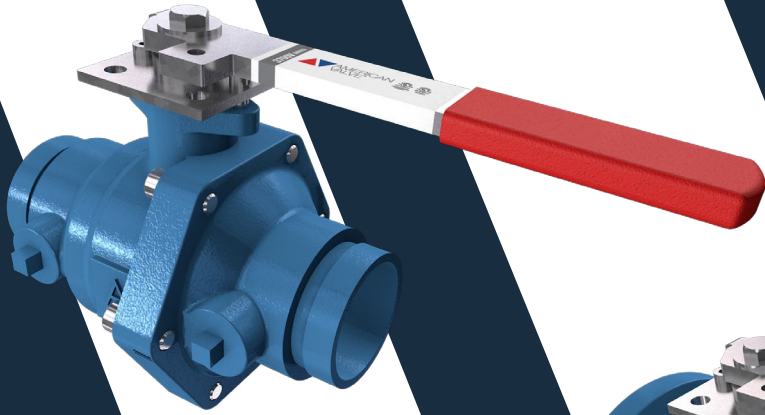

3700

SPECIFICATIONS

- Certified to meet the requirements of NSF/ANSI 61 and NSF/ANSI 372
- PFA*- Fused solid ball
- Same end-to-end as any flanged gate or plug valve
- Tapped and plugged boss allows for venting downstream, or test port for backflow preventer
- 2" through 8" - Full port
- Class VI positive shutoff
- 100% Lead-free
- Low torque
- Ideal for liquid, air, and backflow applications

RATINGS

- 200 W @ 200° F
- This cast iron ball valve has been engineered to replace any IBBM gate valve, all-iron gate valve, or plug valve

*PFA is an ingredient commonly branded as Teflon®.

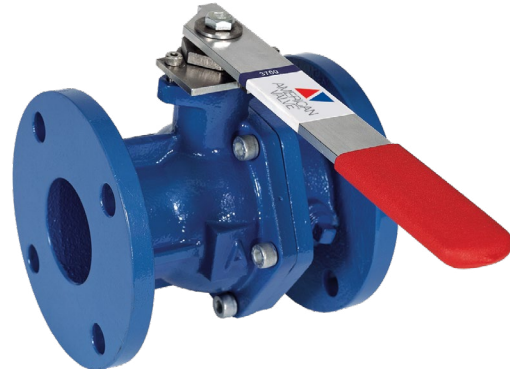

SAMPLE SPECIFICATIONS

Ball valves shall be of the floating-ball design providing bi-directional, tight shutoff in accordance with MSS SP-72. The valves shall be rated 200 psi non-shock at 200deg F. Bodies shall be of cast iron per ASTM A126 Class B, with ANSI Class 125 flat-face flanges. The interior and exterior of the body shall be UL certified polyester powder coated to meet NSF/ANSI 61 and NSF/ANSI 372. The ball shall be PFA infused cast iron, with a stainless steel blowout-proof stem. The seats shall be PTFE and body O-ring Buna-N. Valves shall be equipped with locking handles and one test port as standard. Valves may be equipped with 2" square operating nuts. Valves shall be the Series 3700 as manufactured by American Valve, Inc. or as approved by the engineer.



MATERIAL SPECIFICATIONS

	Part	Material
1	Body	Cast Iron/ASTM A126 Class B
2	Ball	Cast Iron/PFA* Fused ASTM A48 Class-35
3	Stem	Stainless Steel
4	Stop Plate	Steel
5	Handle	Steel
6	Handle Grip	Vinyl Dipped Plastisol
7	Sleeve	Stainless Steel
8	Stem O-Ring	Nitrile Rubber (Buna-N)
9	Shoulder Screw	Steel
10	Stem Bolt/Washer	Steel
11	Seat Ring	Virgin PTFE
12	Back Seat O-Ring	Nitrile Rubber (Buna-N)
13	Socket Head Screw	Steel
14	Body Gasket	Nitrile Rubber (Buna-N)
15	Body Plug	2" - 4": Steel 6" - 8": Cast Iron
16	Collar	Steel
17	Thrust Washer	PTFE
18	Body Cap	Cast Iron/A126 Class B
19	Handle Grip	Red Foam Rubber
20	Body Cap	Cast Iron

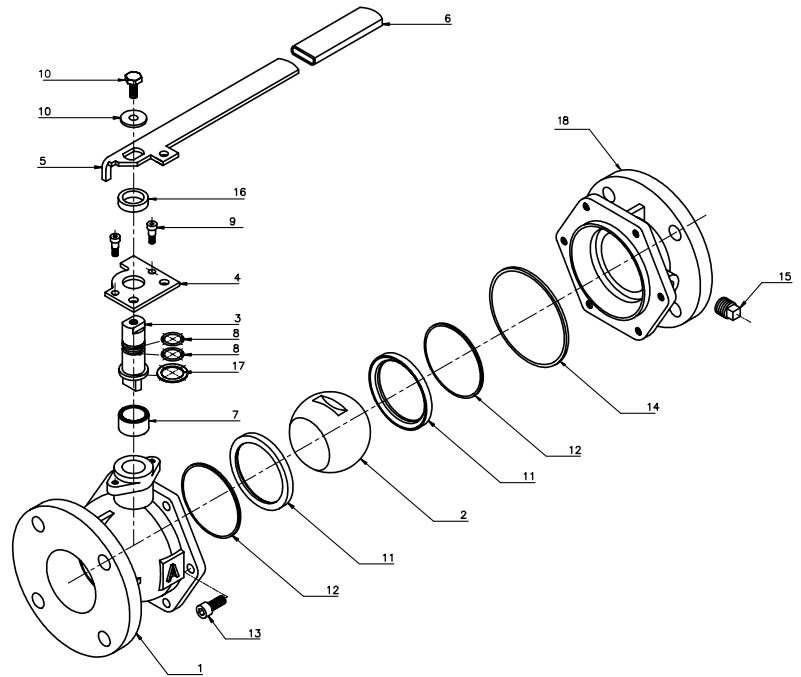

DIMENSIONS

	2"	2½"	3"	4"	6"	8"
A Face to Face	7.00"	7.50"	8.00"	9.00"	10.50"	11.50"
B Center of Port to Top	5.50"	5.22"	5.59"	6.34"	8.31"	9.76"
C Flange Diameter	6.00"	7.00"	7.50"	9.00"	11.00"	13.500"
D Center of Valve to Handle End	12.00"	10.20"	10.90"	12.60"	16.70"	19.70"
E Port Diameter	2.00"	2.50"	3.00"	4.00"	6.00"	8.00"
Bolt Holes	4	4	4	8	8	8
Weight (lbs.)	25	30	38	62	118	199
Pallet Quantity	60	60	48	24	12	8

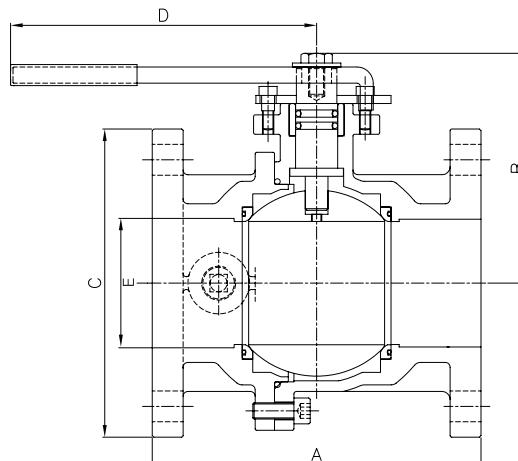



3700V

SPECIFICATIONS

- Certified to meet the requirements of NSF/ANSI 61 and NSF/ANSI 372
- PFA*- Fused solid ball
- Double tapped and plugged bosses allow for venting or draining downstream, or test port for backflow preventer
- Full port in all sizes
- Class VI positive shutoff
- 100% Lead-free
- Low torque
- Ideal for liquid, air, and backflow applications

RATINGS

- 200 W @ 200° F
- This cast iron ball valve has been engineered to replace any plug valve, carbon steel ball valve, or gate valve

**PFA is an ingredient commonly branded as Teflon®.*

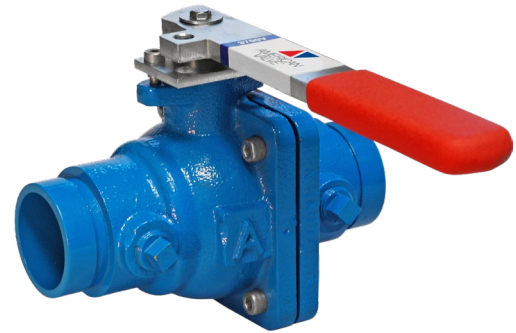

SAMPLE SPECIFICATIONS

Ball valves shall be of the floating-ball design providing bi-directional, tight shutoff in accordance with MSS SP-72. The valves shall be rated 200 psi non-shock at 200deg F. Bodies shall be of cast iron per ASTM A126 Class B, with grooved ends. The interior and exterior of the body shall be UL certified polyester powder coated to meet NSF/ANSI 61 and NSF/ANSI 372. The ball shall be PFA infused cast iron, with a stainless steel blowout-proof stem. The seats shall be PTFE and body O-ring Buna-N. Valves shall be equipped with locking handles and test ports as standard. Valves may be equipped with 2" square operating nuts. Valves shall be the Series 3700V as manufactured by American Valve, Inc. or as approved by the engineer.



MATERIAL SPECIFICATIONS

	Part	Material
1	Body	Cast Iron/ASTM A126 Class B
2	Ball	Cast Iron/PFA* Fused ASTM A48 Class-35
3	Stem	Stainless Steel
4	Stop Plate	Steel
5	Handle	Steel
6	Handle Grip	Vinyl Dipped Plastisol
7	Sleeve	Stainless Steel
8	Stem O-Ring	Nitrile Rubber (Buna-N)
9	Shoulder Screw	Steel
10	Stem Bolt/Washer	Steel
11	Seat	Virgin PTFE
12	Back Seat O-Ring	Nitrile Rubber (Buna-N)
13	Socket Head Screw	Steel
14	Body Gasket	Nitrile Rubber (Buna-N)
15	Body Plug	2" - 4": Steel 6": Cast Iron
16	Collar	Steel
17	Thrust Washer	PTFE
18	Body Cap	Cast Iron/A48 Class 30

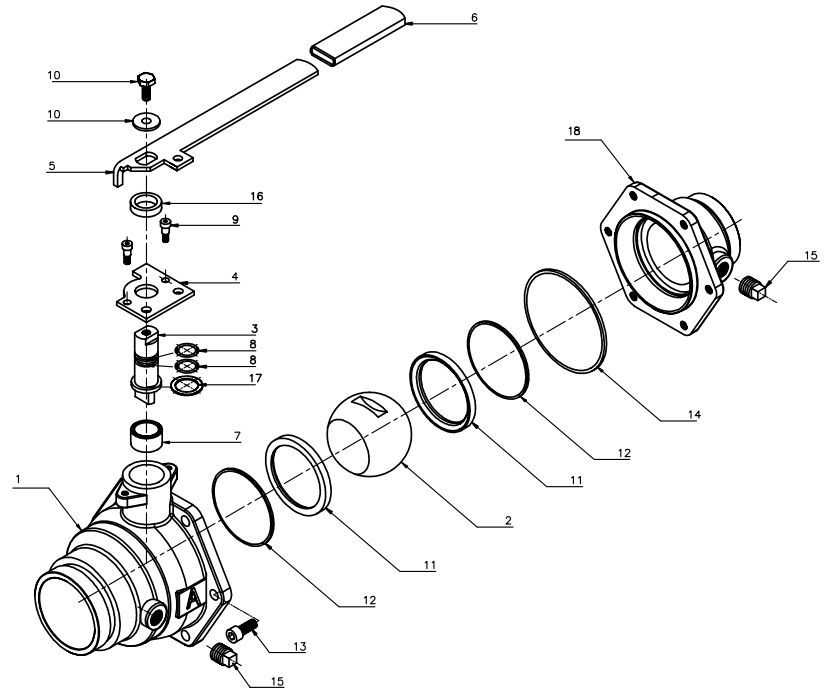

DIMENSIONS

	2"	2½"	3"	4"	6"
A End to End	7.80"	8.64"	8.68"	9.90"	12.56"
B Center of Port to Top	4.37"	5.31"	5.59"	6.34"	8.31"
C Face to Face	5.80"	6.77"	6.81"	7.90"	10.56"
D Center of Valve to Handle End	9.29"	9.76"	9.76"	10.67"	16.79"
E Port Diameter	2.00	2.50"	3.00"	4.00"	6.00
F Groove Diameter	2.24"	2.72"	3.34"	4.33"	6.45"
G Gasket Seat	0.63"	0.63"	0.63"	0.63"	0.63"
H Groove Width	0.31"	0.31"	0.31"	0.37"	0.38"
I Groove Depth	0.06"	0.08"	0.08"	0.08"	0.09"
J Grooved End OD	2.37"	2.87"	3.50"	4.5"	6.63"
Weight (lbs.)	12	19	26	45	105
Pallet Quantity	60	60	48	24	12

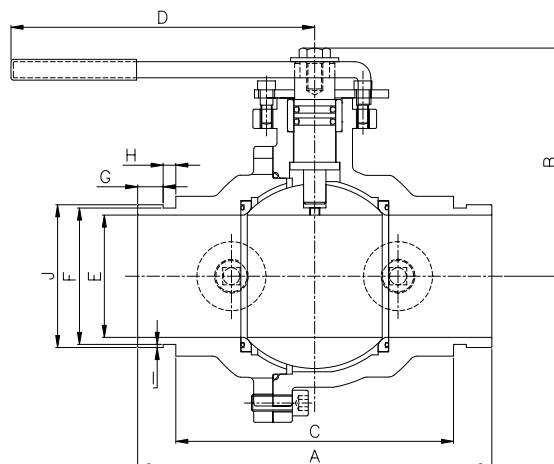



ADVANTAGES

of the 3700 Series Ball Valve

American Valve's 3700 Series™ provides the best alternative to gate valves, exactly matching their end-to-end and flanged dimensions. 3700 Series™ valves also provide superior performance to butterfly and plug valves.

Unlike gate, plug, and butterfly valves, 3700 Series™ valves are designed to maintain a bubble-tight shut off that exceeds ANSI Class VI for many years, even if the valve has not been operated or maintained regularly.

The 3700 Series™ valves are certified to meet the requirements of NSF/ANSI 61 and NSF/ANSI 372. All 3700 Series™ valves are rated at 200 psig @ 200° F, and are full port in all sizes.

3700 Series™ features PFA* seats. It should not be used in steam, oil, or flammable gas applications, but is ideally suited for potable water, wastewater, or other liquids and compressed air.

3700 Series™ has no bronze parts, which contain lead. As regulatory agencies continue to reduce the allowable lead content of components in our drinking water supply, 3700 Series™ offers a safe alternative to IBBM gate valves and bronze disc butterfly valves. 3700 Series™ also features a VOC-free coating.

3700 Series™ valves are bi-directional; flow may go in either direction. They may be mounted horizontally, vertically, or at an angle.

3700 Series™ can be locked in either the open or closed position. 2" square operating nuts are available for underground service or hard-to-reach installations. Gear operators and actuators are available with our 3700 Series™ ball valve.

**PFA is an ingredient commonly branded as Teflon®*

GATE VALVE COMPARISON

Typical Gate Valve	3700 Series™
Class IV Allowable Leak-Rate	Positive Shutoff - Exceeds Class VI
Same end-to-end dimensions as Model 3700 (ANSI B16.10)	Same end-to-end dimensions as Class 125 or 150 Gate Valve (ANSI B16.10) or Plug Valve
Unprotected Metal Gate Notorious as a magnet for buildup and mineral deposits, making full shutoff impossible. Should come with a cheater bar.	PFA*-Fused Ball Prevents calcium, lime, or any other buildup common in water applications, which often leads to premature valve failure.
Heavy & Awkward <ul style="list-style-type: none"> • Requires "Big Joe" to Install • Typical 3" Gate Valve = 72 lbs. • Typical 6" Gate Valve = 197 lbs. 	Lightweight & Compact <ul style="list-style-type: none"> • Easy to Install • 3" 3700 = 35 lbs. • 6" 3700 = 113 lbs.
Contains bronze parts ... which contain lead. (Lead has been shown to cause birth defects and damage to the nervous system, even in small doses.)	100% Lead-Free <ul style="list-style-type: none"> • No bronze parts • No VOCs. Certified to meet the requirements of NSF/ANSI 61 and NSF/ANSI 372.



3700 PFA*-FUSED BALL

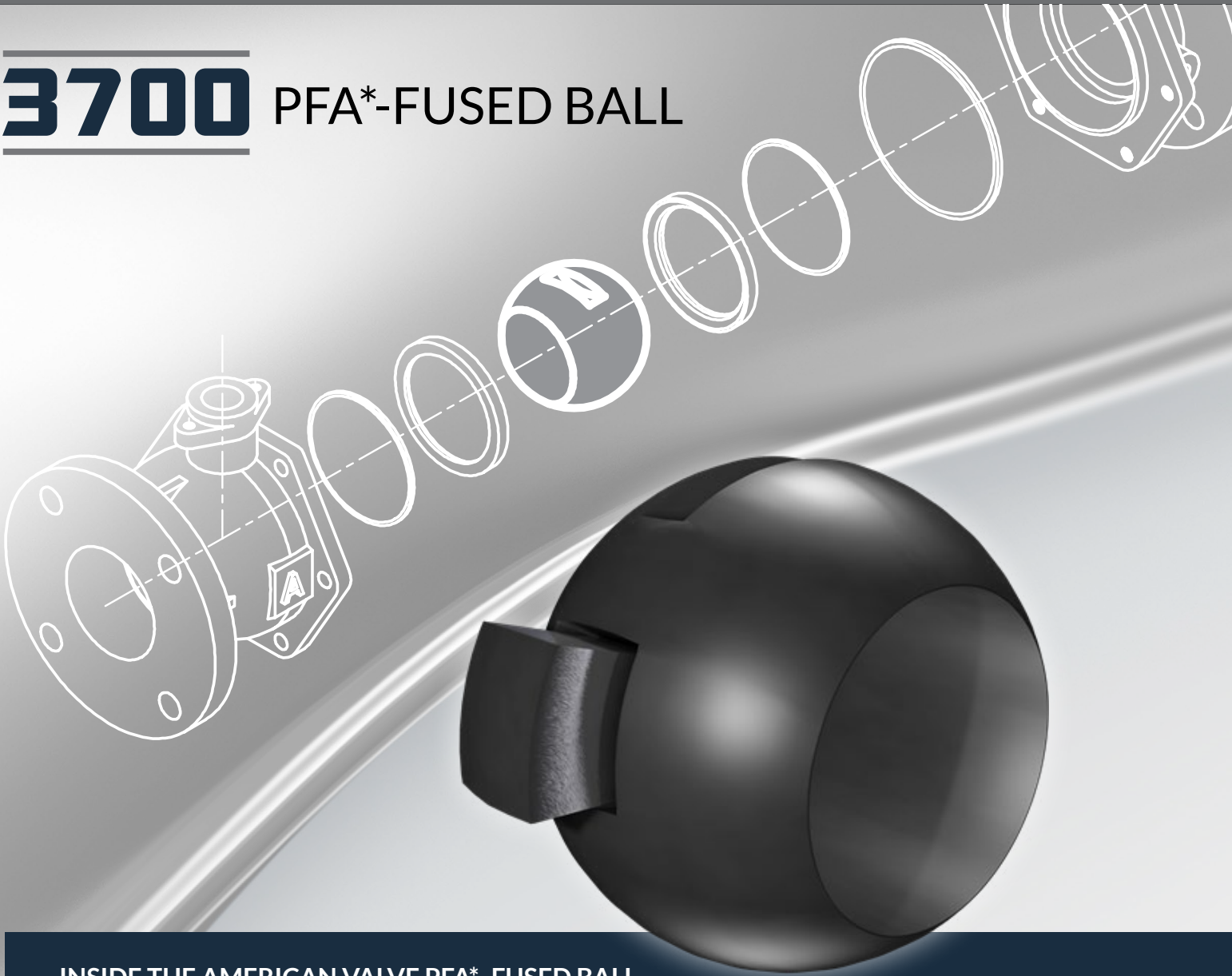

INSIDE THE AMERICAN VALVE PFA*- FUSED BALL

- More corrosion-resistant than balls made with unprotected metal surfaces. (Refer to any manufacturer's chemical resistance guide for further information.)
- Inhibits the buildup of lime, calcium, sludge, etc. that accumulates on a ball's surface and prevents premature failure of the valve seats.
- Series 4000 valves with PFA*-fused balls can last up to ten times longer than valves made with unprotected ball surfaces.
- The lubricity of the PFA*-fused ball allows for lower torque ratings in any application, and eliminates ball pitting, prevents buildup, lowers torque, and stops premature valve failure.
- Since PFA* is actually impregnated .008" into the solid metal, it can't wear, chip, or flake off.

AMERICAN VALVE

4321 PIEDMONT PARKWAY,
GREENSBORO, NC 27410

PHONE: 800-645-0101

EMAIL: SALES@AMERICANVALVE.COM

3700 SERIES

AV CATALOG 3700 SERIES V2 0519